

FT120

Fully Solid-State Short-Range Blind Spot Lidar User Manual

Classification: Public

Doc Version: F01-en-240710

Table of Contents

■ About this manual	1
Access to this manual	1
Technical support	1
Legends and format	1
■ Safety notice	2
Special warnings	2
Operating environment	3
Personnel	5
Installation and operation	6
Repair	9
1. Introduction	10
1.1. Applicability	10
1.2. Operating principle	10
1.3. Basic structure	11
1.4. Field of View	13
1.5. Specifications	16
2. Setup	19
2.1. Mechanical installation	19
2.1.1. Exterior dimensions	19
2.2. Electrical interface	21
2.2.1. Pin description	21
2.2.2. Connector use	22
2.2.3. Cables (Ethernet)	23
2.3. Connection box (optional)	24

2.3.1. Ports	26
2.3.2. Connection	28
2.4. Network settings on the receiving host	30
2.5. Tools	30
3. Data structure	31
3.1. Point Cloud Data Packet	32
3.1.1. Ethernet header	32
3.1.2. Point cloud UDP data	33
3.1.3. Ethernet tail	37
3.1.4. Point cloud data analysis method	38
4. Parameter interfaces	40
4.1. Internet connection	40
4.1.1. Source	40
4.1.2. Destination	41
4.2. Functional settings	43
4.3. State settings	44
4.4. Time sync	46
4.5. Lidar info	48
4.6. Operation statistics	49
4.7. Upgrade	50
5. Communication protocol	51
6. Maintenance	51
7. Troubleshooting	53
Appendix A: Performance distribution	55
Appendix B: Absolute time of point cloud data	56
B.1. Source of absolute time	56

B.1.1. PTP as the clock source	56
B.2. Absolute time of Point Cloud Data Packets	57
Appendix C: Angle correction	58
C.1. Data format	58
Appendix D: Legal notice	61

■ About this manual

Please make sure to read through this user manual before your first use and follow the instructions herein when you operate the product. Failure to comply with the instructions may result in product damage, property loss, personal injuries, and/or a breach of warranty.

Access to this manual

To obtain the latest version, please do one of the following:

- Contact your sales representative of Hesai.
- Contact Hesai technical support: service@hesaitech.com

Technical support

If your question is not addressed in this user manual, please contact us at:

- service@hesaitech.com
- <https://www.hesaitech.com/technical-support/>
- <https://github.com/HesaiTechnology>

Legends and format

 **Warnings:** Instructions that must be followed to ensure safe and proper use of the product.

 **Notes:** Additional information that may be helpful.

Monospace font: field names

For example: **Distance** represents the Distance field.

■ Safety notice

- Please make sure to read through this safety notice and follow all the instructions and warnings. Failure to comply with the instructions and warnings may result in product damage, property loss, and/or personal injuries.
- Please check the certification information on the product's nameplate and read through the corresponding certification warnings. If specific users require not presenting certification information on the nameplate, please follow the agreed-to arrangements.
- If you incorporate this lidar product into your product(s), you are required to provide this user manual (or access to this user manual) to the intended users of your product(s).
- This lidar product is intended as a component of an end product. It is the responsibility of the end-product supplier to assess the risk of use in accordance with applicable standards and inform the intended user of safety-related information.
- Should there be other agreements with specific users, the other agreements shall apply.
- Before using a product, please confirm with Hesai the development maturity of the product in a timely manner. For products still in development, Hesai makes no warranty of non-infringement nor assumes any responsibility for quality assurance.

Special warnings

Laser safety

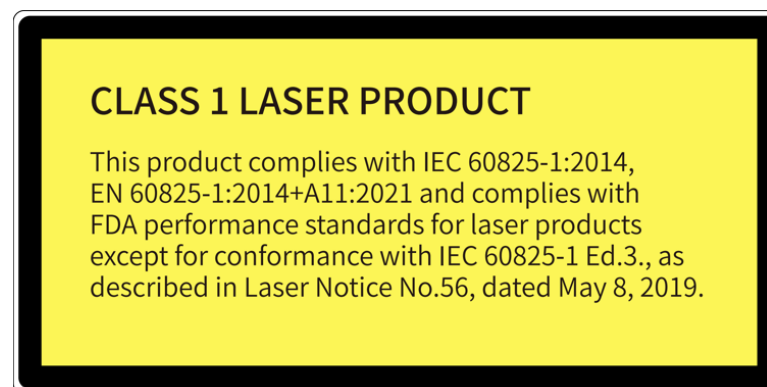

Hot surface



Hot parts!

Burned fingers when handling the parts.

Wait one-half hour after switching off before handling the parts.

Abnormalities

In any of the circumstances listed below, stop using the product immediately:

- If you suspect malfunctions of or damage to the product, with symptoms such as significant noise or visible vibration.
- If you or people in the nearby environment feel discomfort.
- If any device or equipment in the nearby environment malfunctions.

Meanwhile, contact Hesai or an authorized Hesai service provider for more information on product disposal.

Prohibition of disassembly

Unless expressly agreed to in writing by Hesai, do NOT disassemble the product.

Operating environment

Radio frequency (RF) interference

- Before using the product, make sure to read all the signs and notices on the product enclosure (including the nameplate). If specific users require not presenting certification information on the nameplate, please follow the agreed-to arrangements.
- Although the product is designed, tested, and manufactured to comply with the regulations on RF radiation (such as FCC, CE-EMC, or KCC), the radiation from the product may still influence electronic devices.

Vibration

- If significant mechanical shocks and vibration exist in the product's operating environment, please contact Hesai's technical support to obtain the shock and vibration limits of your product model. Exposure to over-the-limit shocks or vibration may damage the product.
- Make sure to package the product in shock-proof materials to avoid damage during transport.

Explosive atmosphere and other air conditions

- Do NOT use the product in any area where potentially explosive atmospheres are present, such as environments with high concentrations of flammable chemicals, vapors, or particulates (including particles, dust, and metal powder) in the air.
- Do NOT expose the product to environments having high concentrations of industrial chemicals, including liquefied gases that are easily vaporized (such as helium). Such exposure can damage or impair product functionality.

Chemical environment

Do NOT expose the product to corrosive or strong polar chemical environments (such as liquids or gases), including but not limited to strong acids, strong bases, esters, and ethers. This is to avoid damage to the product (including but not limited to water resistance failure).

Ingress protection (IP)

Please check the product's user manual for its IP rating (refer to [Section 1.5, Specifications](#)). Make sure to avoid any ingress beyond that rating.

Operating temperature

Please check the product's user manual for its operating temperature (refer to [Section 1.5, Specifications](#)). Make sure not to exceed the operating temperature range.

Recommended storage conditions

Please store the product in a dry and well-ventilated place. The recommended ambient temperature is $23 \pm 5^{\circ}\text{C}$, and the humidity is between 30% and 70%.

Light interference

Certain precision optical instruments may interfere with the laser light emitted from the product. Please check all the instructions for these instruments and take preventive measures if necessary. For example, protective leather covers are provided for certain product models; when these lidars are temporarily not used for measurement, the leather covers can be applied to block laser light emission.

Personnel

Recommended operator qualifications

The product should be operated by professionals with engineering backgrounds or experience in operating optical, electrical, and mechanical instruments. Please follow the instructions in this manual when operating the product and contact Hesai technical support if needed.

Medical device interference

- Some components in the product can emit electromagnetic fields. If the product operators or people in the nearby environment wear medical devices (such as cochlear implants, implanted pacemakers, and defibrillators), make sure to consult the physicians and medical device manufacturers for medical advice, such as determining whether keeping the product a safe distance away from the medical devices is needed.
- If you suspect that the product is interfering with your medical device, stop using the product immediately.

Installation and operation

Power supply

- Before powering on the product, make sure the electrical interfaces are dry and clean. Do NOT power on the product in humid conditions.
- Do NOT use out-of-spec or damaged cables or adapters.
- You are recommended to use only the cables and power adapters provided by Hesai. If you are to design, configure, or select the power supply system (including cables) for the product, make sure to comply with the electrical specifications in the product's user manual (refer to [Section 1.5, Specifications](#) and the Power Supply Requirements section if available); for technical support, please contact Hesai.
- Please check [Section 2.2, Electrical interface](#) and strictly follow the instructions on plugging/unplugging the connector. If abnormalities already exist (such as bent pins, broken cables, and loose screws), stop using the product and contact Hesai technical support.

Eye safety

The product is a Class 1 laser product. It satisfies the requirements of:

- IEC 60825-1:2014
- EN 60825-1:2014+A11:2021
- 21 CFR 1040.10 and 1040.11 except for deviations (IEC 60825-1 Ed.3) pursuant to Laser Notice No.56, dated May 8, 2019.

CAUTION: Use of controls or adjustments or performance of procedures other than those specified herein may result in hazardous radiation exposure.

CAUTION

- For maximum self-protection, it is strongly warned that users do NOT look into the transmitting laser through a magnifying product (microscope, eye loupe, magnifying glass, etc.).
- This product does not have a power switch. It starts operating once connected to power. During operation, the entire optical window can be regarded as the product's laser emitting window; looking at the optical window can be regarded as looking into transmitting laser.

FCC Compliance

This device complies with part 15 of the FCC Rules. Operation is subject to the following two conditions: (1) This device may not cause harmful interference, and (2) this device must accept any interference received, including interference that may cause undesired operation.

Product enclosure

- The product contains metal, glass, plastic, as well as sensitive electronic components. If the product is dropped or burnt, stop using it immediately and contact Hesai technical support.
- Do NOT squeeze or pierce the product. If the product enclosure is broken, stop using it immediately and contact Hesai technical support.
- Certain product models contain high-speed rotating parts. To avoid potential injuries, do NOT operate the product if the enclosure is loose.
- If the product enclosure consists of fins or grooves, please wear gloves when handling the product. Applying too much pressure with your bare hands may cause cuts, bruises or other injuries.

Optical window



The location of the optical window is illustrated in [Section 1, Introduction](#).

- Do NOT apply protective film, wax or any other substance on the optical window.
- To keep the product's optical window from fingerprints and other stains, do NOT touch the optical window with bare hands. If the optical window is already stained, please refer to the cleaning method in [Section 6, Maintenance](#).
- To prevent scratches, do NOT touch the product's optical window with hard or sharp objects. If scratches already exist, stop using the product and contact Hesai technical support. Severe scratches may affect the quality of the product's point cloud data.

Mounting

- Before operating the product, make sure it is properly and securely mounted. The mounting should prevent the product from leaving its mounting position under external forces (such as collisions, high winds, and stone impacts).
- Before installing any exterior part, please ensure that each exterior part and its movable area do not overlap the Field of View (FOV) of the lidar.

 The FOV of lidar is the spatial angular range bounded by the horizontal and vertical FOV ranges (see [Section 1.5, Specifications](#)); the distance to the origin of the lidar's coordinate system is not limited. For inquiries about the FOV, please contact Hesai technical support.

Hot surface

During operation or the time period after the operation, the product's enclosure can be hot.

- To prevent discomfort or even burns, do NOT touch the product's enclosure with your skin.
- To prevent fires, make sure to keep flammable materials away from the product's enclosure.

Certain product models support active heating of the optical window to reduce the impact of ice and frost.

- While active heating is ON, please avoid direct skin contact with the optical window.
- Users can turn off active heating.

Peripherals

The product may be used along with accessories and devices, such as suction cup mounts, extension cables, power supplies, network devices, GPS/PTP devices, CAN transceivers, and cleaning equipment.

When selecting a peripheral, please refer to all relevant specifications in the product's user manual or contact Hesai technical support. Using out-of-spec or unsuitable devices may result in product damage or even personal injuries.

Firmware and software upgrading

Make sure to use only the upgrade files provided by Hesai. Make sure to observe all the instructions provided for that upgrade file.

Customized firmware and software

- Before using a customized version of firmware and software, please fully understand the differences in functions and performance between the customized version and the standard version.
- Make sure to strictly follow all the instructions and safety precautions provided for that customized version. If the product does not function as anticipated, stop using the product immediately and contact Hesai technical support.

Point cloud data processing

- Certain product models support one or more point cloud data processing functions, including but not limited to: Noise Filtering, Interstitial Points Filtering, Retro Multi-Reflection Filtering, and Non-Linear Reflectivity Mapping.
- These functions are configurable and are intended only to assist the user in extracting information from the point cloud data. Users are in full control of whether to use any of these functions. Moreover, users are responsible for analyzing the product's intended application scenarios and evaluating the risk of enabling one or more of these functions in combination.
- To learn about the supported functions of a product model, please contact Hesai technical support.

Repair

- Unless expressly agreed to in writing by Hesai, do NOT disassemble, repair, modify, or retrofit the product by yourself or entrust any third party to do so. Such a breach:
 - can result in product damage (including but not limited to water resistance failure), property loss, and/or injuries;
 - shall constitute a breach of warranty.
- For more product repair issues, please contact Hesai or an authorized Hesai service provider.

1. Introduction

1.1. Applicability

This manual applies to the following versions:

Software	c.00.pt5 or later
Firmware	1.02.017 or later
Config parameters	1.02.011 or later

1.2. Operating principle

Distance measurement: Time of Flight (ToF)

1. A laser diode emits a beam of ultrashort laser pulses onto the target object.
2. The laser pulses are reflected after hitting the target object. The returning beam is detected by an optical sensor.
3. Distance to the object can be accurately measured by calculating the time between laser emission and receipt.

$$d = \frac{ct}{2}$$

d: Distance

c: Speed of light

t: Travel time of the laser beam

1.3. Basic structure

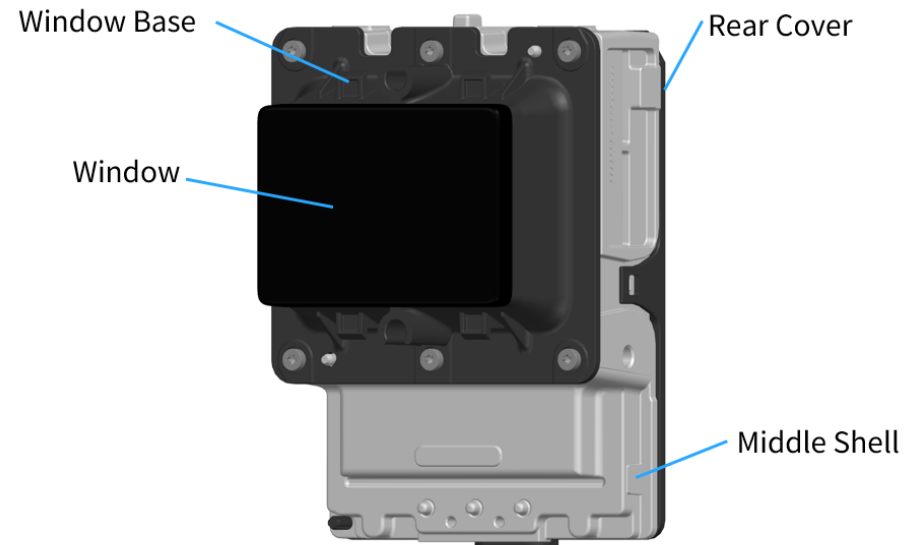

Figure 1. Axonometric view

The lidar structure is shown in [Figure 1](#).

The lidar's coordinate system is illustrated in [Figure 3](#) and [Figure 4](#). All measurements are relative to the origin (Point O), which is also the optical center.

Lidar azimuthal position is defined in [Figure 4](#). Y-axis corresponds to 0°. The clockwise direction (in the top view) is defined as positive.

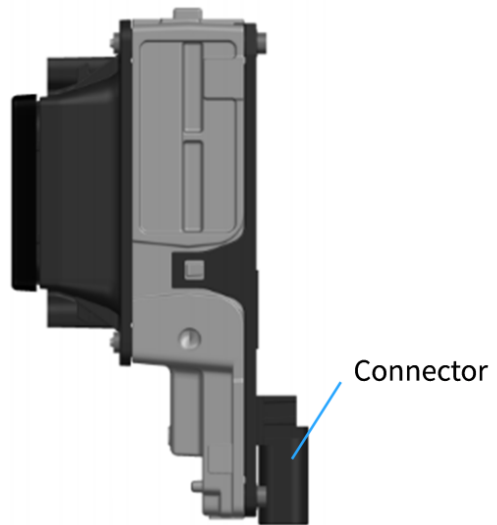

Figure 2. Right view

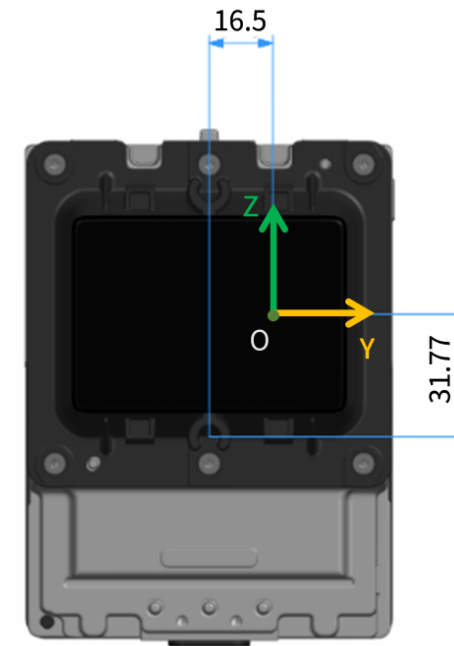

Figure 3. Front view (unit: mm)

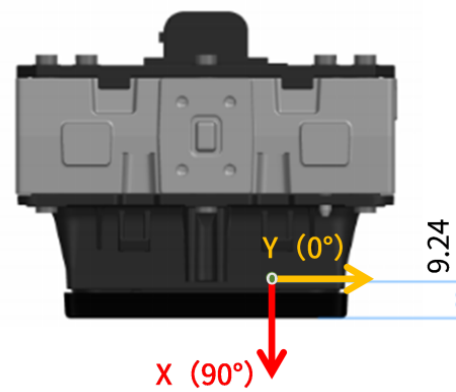

Figure 4. Top view (unit: mm)

1.4. Field of View

The lidar's Field of View (FOV) can be simplified to the red rectangle in [Figure 5](#).

All column channels and row channels are uniformly distributed; the design values of horizontal and vertical angular resolutions are 0.625° .

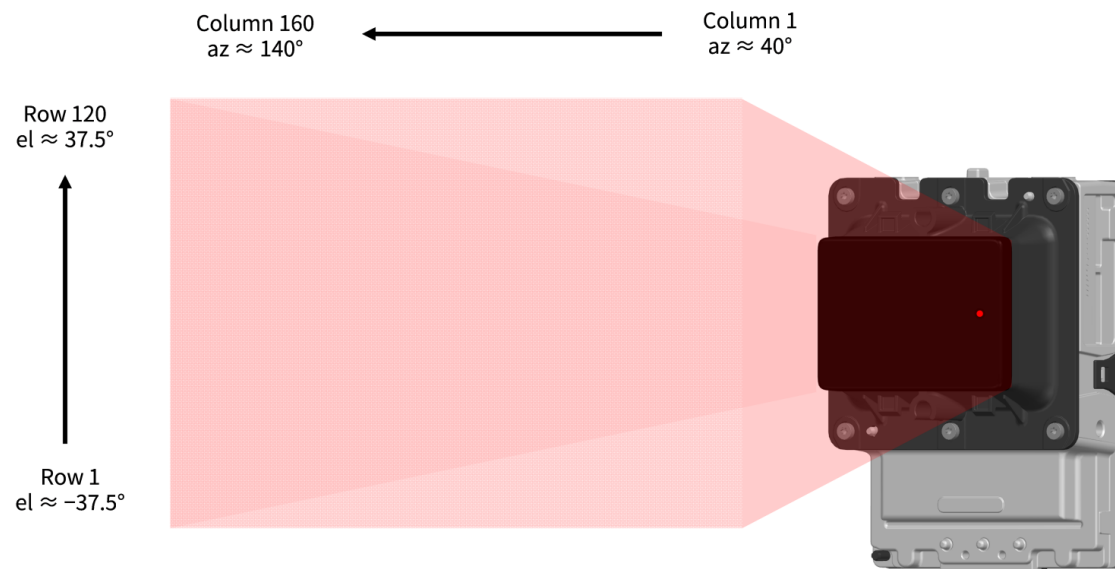

Figure 5. Simplified illustration of the FOV

i Each channel has an intrinsic angle offset, both horizontally and vertically. These angles are recorded in this lidar unit's angle correction file (see [Appendix C, Angle correction](#))

The spherical and planar projections of the actual FOV are shown in [Figure 6](#), [Figure 7](#) and [Figure 8](#).

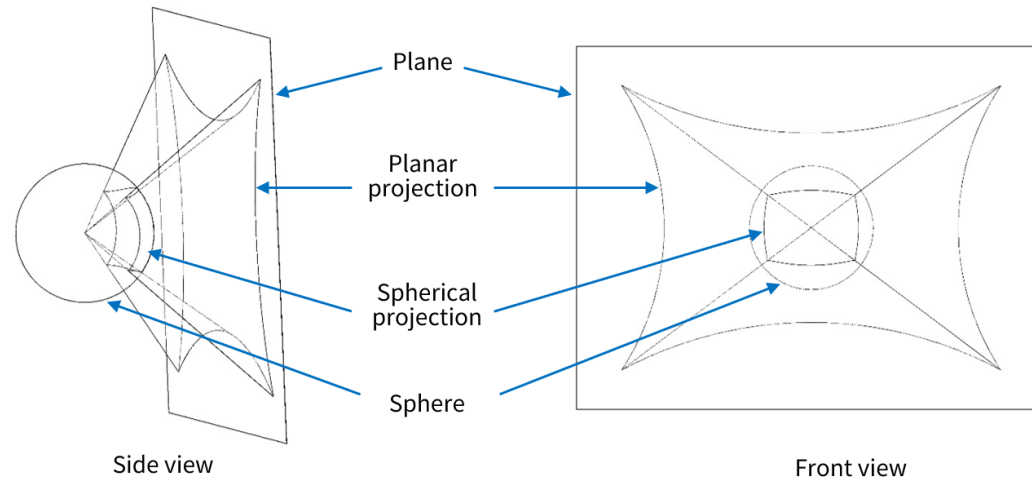

Figure 6. Spherical and planar projections of the actual FOV

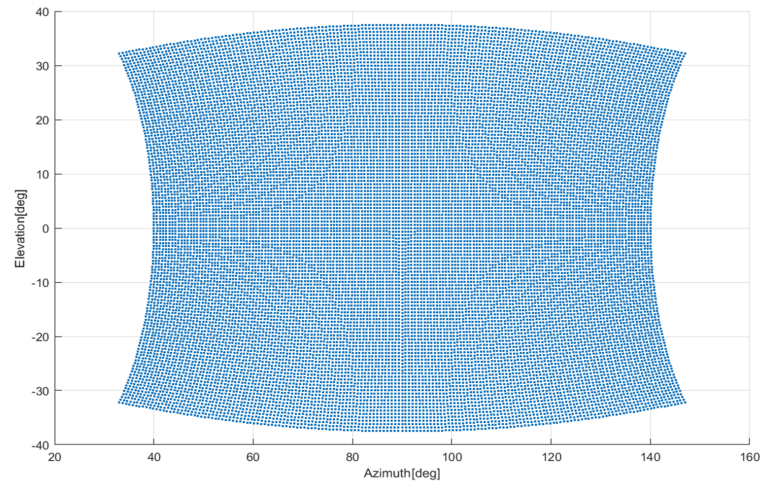

Figure 7. FOV projection on the angular plane of the spherical coordinate system

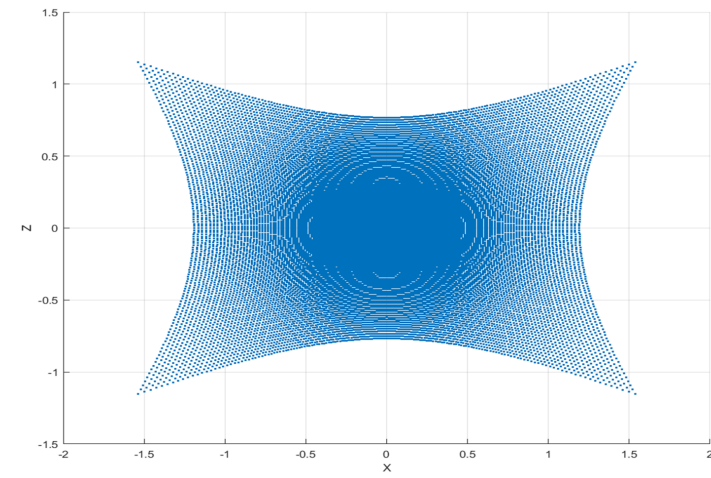

Figure 8. FOV projection on the angular plane of the Cartesian coordinate system

1.5. Specifications

SENSOR

Scanning method	Electronic scanning (fully solid-state)
Ranging capability	0.1 to 22 m (at 10% reflectivity)
Ranging accuracy	±5 cm (typical)
Ranging precision	5 cm (1σ)
Horizontal FOV	100°
Horizontal resolution	0.625°
Vertical FOV	75° (-37.5° to +37.5°)
Vertical resolution	0.625°
Frame rate	10 Hz
Return mode ①	Single Return: Strongest, First Dual Return: First and Strongest

MECHANICAL/ELECTRICAL/OPERATIONAL

Wavelength	940 nm
Laser class	Class 1 Eye Safe
Ingress protection	IP6K7 & IP6K9K
Dimensions ②	95.79 × 76.84 × 134.08 (WDH, mm)
Rated Voltage Range	DC 9 to 16 V
Power Consumption ③	< 15 W

Operating temperature	-40°C to 85°C
Storage temperature	-40°C to 95°C
Weight ②	0.7 kg

DATA I/O

Data transmission	Automotive Ethernet 100BASE-T1, slave mode
Measurements	Distance and reflectivity
Valid data points	Single Return: 192 000 points/sec
Point cloud data rate ④	Single Return: 9.22 Mbps
Clock source	PTP (802.1AS Automotive, 802.1AS AUTOSAR)
PTP clock accuracy	≤1 μs
PTP clock drift	≤5 μs/s

 Specifications are subject to change. Please refer to the latest version of this manual.

Notes to specifications

- ① **Return mode** Only the Single Return (Strongest) mode is recommended for this version.
- ② **Dimensions and weight**
 - The height and depth include the connector.
 - May be different for customized models. The mechanical drawings and data exclusively provided for customized models shall prevail.
- ③ **Power consumption**
 - Typical value, not including accessories such as the connection box.
 - The external power supply should be able to provide at least 15 W.

④ **Point cloud data rate** Not including Fault Message Packets (around 100 bytes per packet, sent every 5 ms).

2. Setup

Before operating the lidar, strip away the transparent protective film on the optical window.



The information in this section may be different for customized models. The mechanical drawings and data exclusively provided for customized models shall prevail.

2.1. Mechanical installation

2.1.1. Exterior dimensions

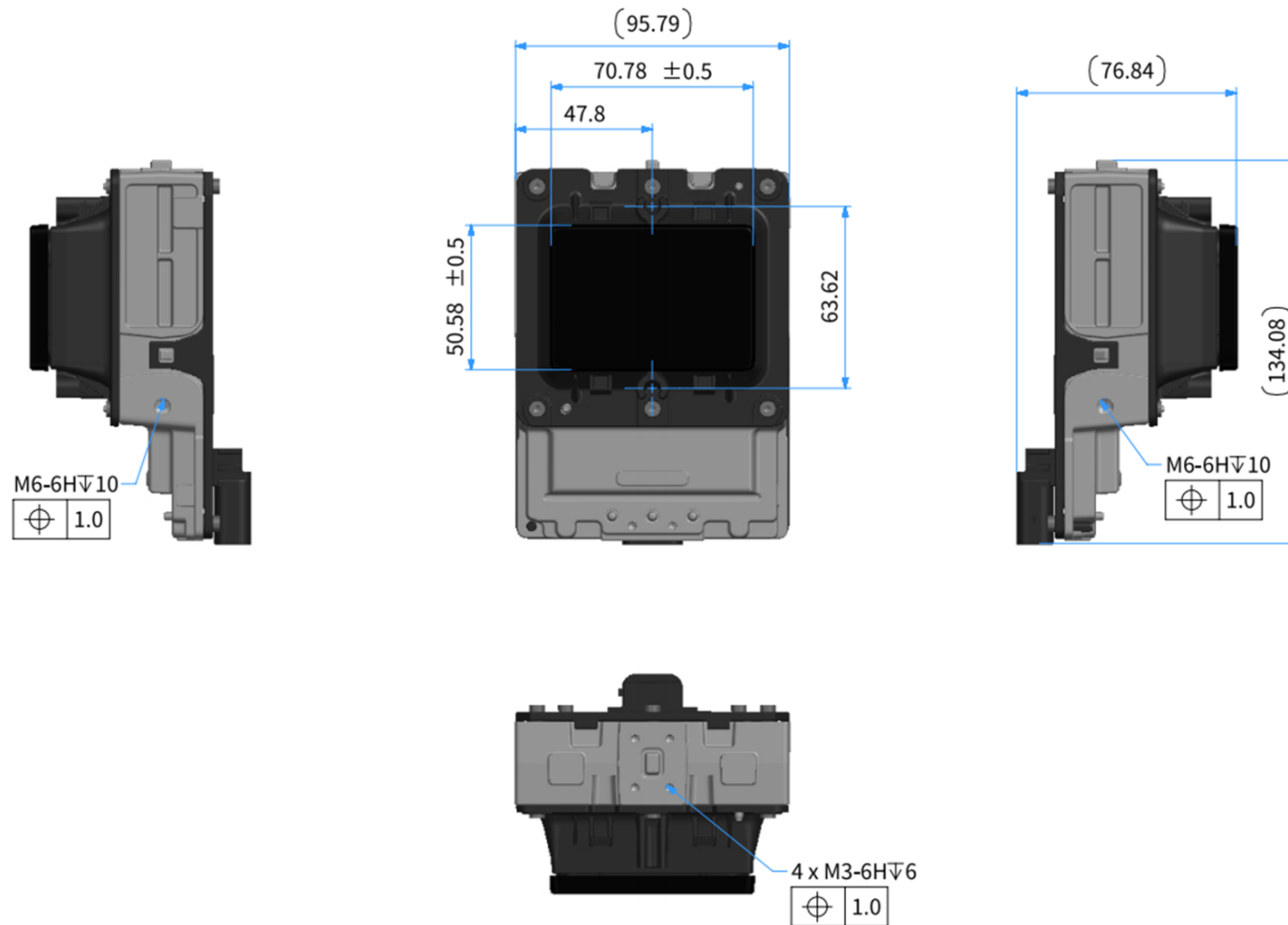

Figure 9. Dimensions (unit: mm)

The recommended positioning feature is marked by the red arrows.

The dimensional chain from these two positioning structures to the optical window (exterior) is relatively short, leading to higher mounting accuracy.

2.2. Electrical interface

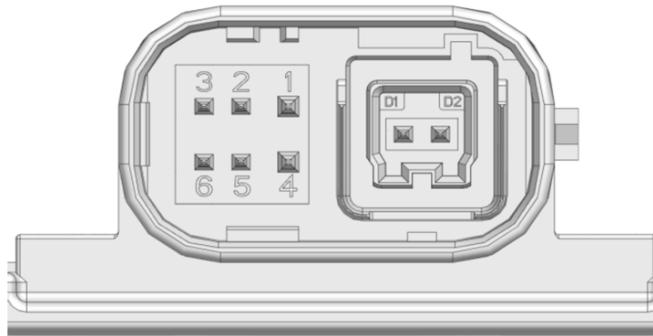

Figure 10. Connector (male socket)

2.2.1. Pin description

Pin description

No.	Signal	Voltage	No.	Signal	Voltage
1	VCC	9 to 16 V	5	Reserved	-
2	Reserved	-	6	Reserved	-
3	Reserved	-	D2	MDI-P	-
4	GND	0 V	D1	MDI-N	-



Please avoid touching the reserved pins with bare hands.

2.2.2. Connector use

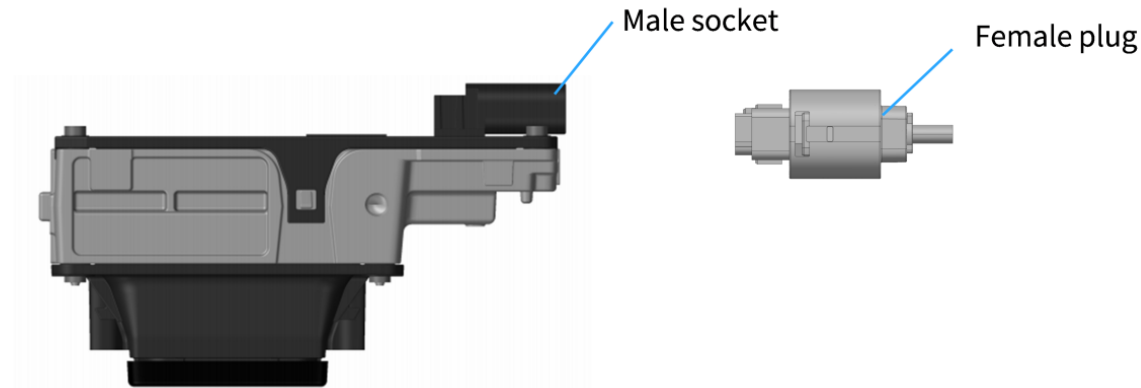

Figure 11. Connector

Connection	<ol style="list-style-type: none"> 1. Turn off the power source. 2. Make sure the plug's red CPA is on the same side as the socket's locking nose. 3. Push the plug straight into the socket until you feel and hear a click. 4. Push the red CPA towards the socket until you feel and hear a click.
Disconnection	<ol style="list-style-type: none"> 1. Turn off the power source. 2. Pull the red CPA away from the socket until you feel and hear a click. 3. Depress the black locking latch; then pull the plug from the socket.



- Before connection, check the pins on the socket and the holes on the plug. In case of bent pins or damaged holes, stop using the connector and contact technical support.
- To prevent breakdowns, turn off the power source before connection and disconnection.
- Do NOT attempt to force open a connection by pulling on the cables or by twisting the connectors in any way. Doing so can loosen the connectors' shells, or even damage the contacts.
- If the connector's shell is accidentally pulled off, stop using the connector and contact Hesai technical support.

- Do NOT attempt to assemble the connector's shell and cable collet; do NOT connect a connector without its shell. Doing so may damage the lidar's circuits.
- For further troubleshooting, please contact Hesai's technical support or obtain work instructions from the connector manufacturer.
- The connector is designed to withstand at least 10 mating cycles; exceeding this number may increase the risk of connector damage.

2.2.3. Cables (Ethernet)

Outside diameter (OD) = 4.10 ± 0.20 mm

Minimum bend radius:

- Single: $5 \times OD$
- Multiple: $15 \times OD$

2.3. Connection box (optional)

Users may connect the lidar with or without a connection box.

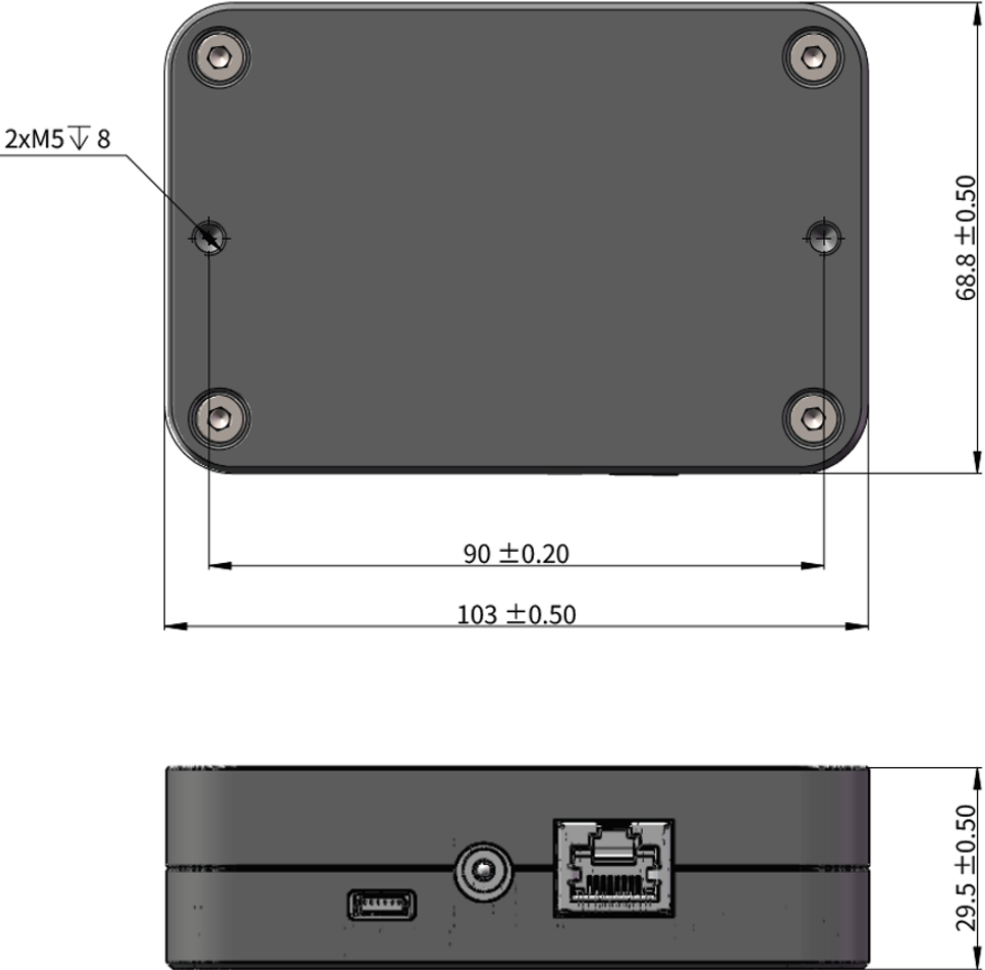

Figure 12. Connection box (unit: mm)

An additional cable is used for connecting the lidar (on the left) and the connection box (on the right), as shown below.

i One cable's head cannot connect to another cable's tail, so each lidar can only use one cable.

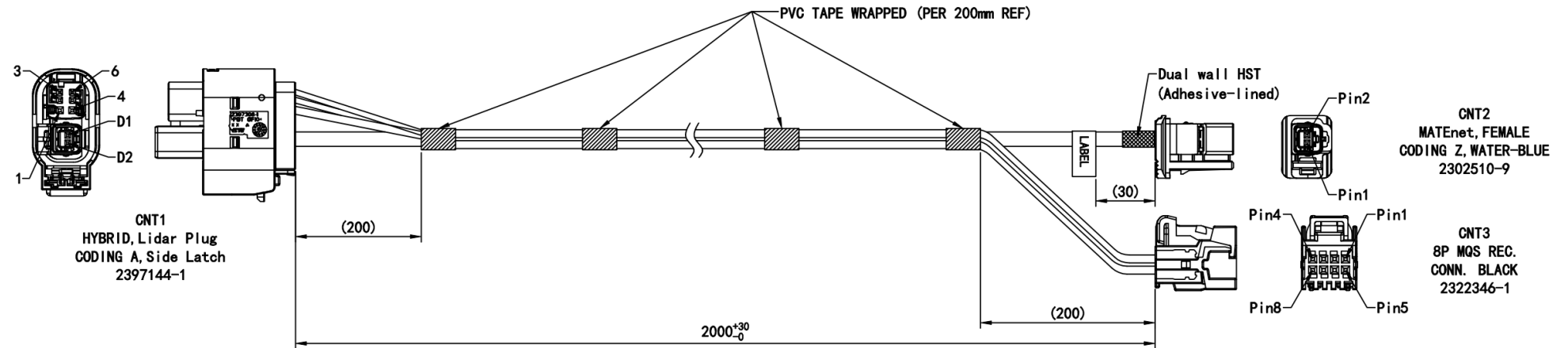

Figure 13. Cable between lidar and connection box (unit: mm)

The wire colors and cross-sectional areas are shown below:

Pin No. on CNT1	Pin No. on CNT3	Signal	Wire color	Wire cross section
Pin 1	Pin 4	VCC	Red	0.75 mm ²
Pin 4	Pin 8	GND	Black	0.75 mm ²
Pin No. on CNT1	Pin No. on CNT 2	Signal	Wire color	
D2	Pin 1	MDI-P	White	
D1	Pin 2	MDI-N	Green	

2.3.1. Ports

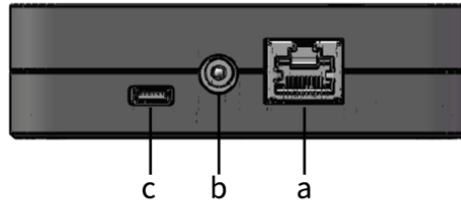

Figure 14. Connection box (front)

Port No.	Port name	Description
a	Standard Ethernet port	RJ45, 100 Mbps Ethernet
b	Power port	Connects to a DC-005 DC adapter.
c	Reserved port	Do NOT connect this port to external signals.

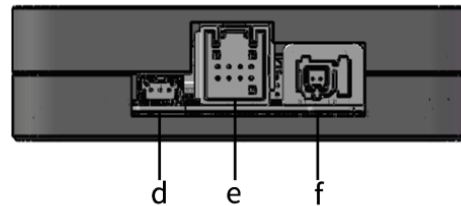

Figure 15. Connection box (back)

Port No.	Port name	Description
d	Reserved port	Do not connect this port to external signals.
e	Power Output port	See CNT3 in Figure 13 , “Cable between lidar and connection box (unit: mm)” .

Port No.	Port name	Description
f	Automotive Ethernet port	See CNT 2 in Figure 13 , “Cable between lidar and connection box (unit: mm)” .

2.3.2. Connection

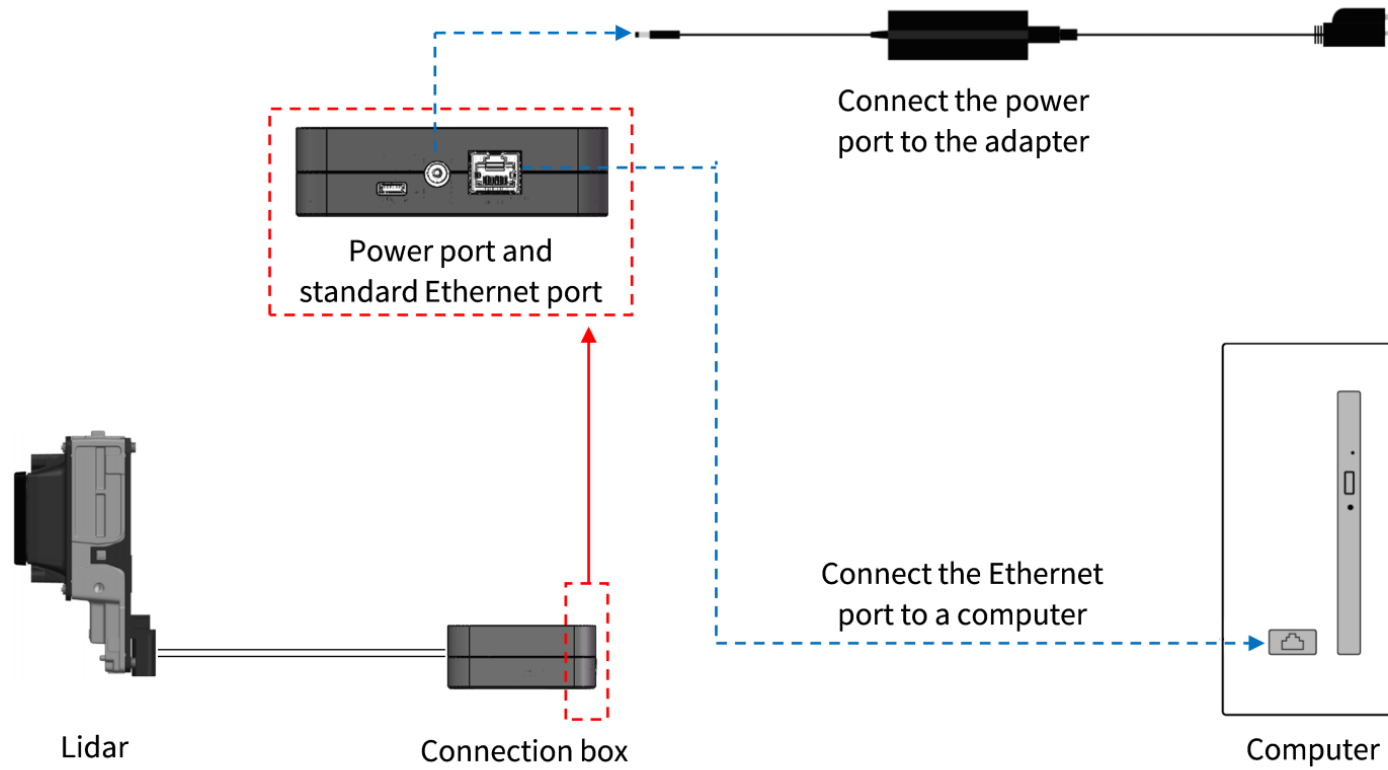

Figure 16. Connection with PTP (software simulation)

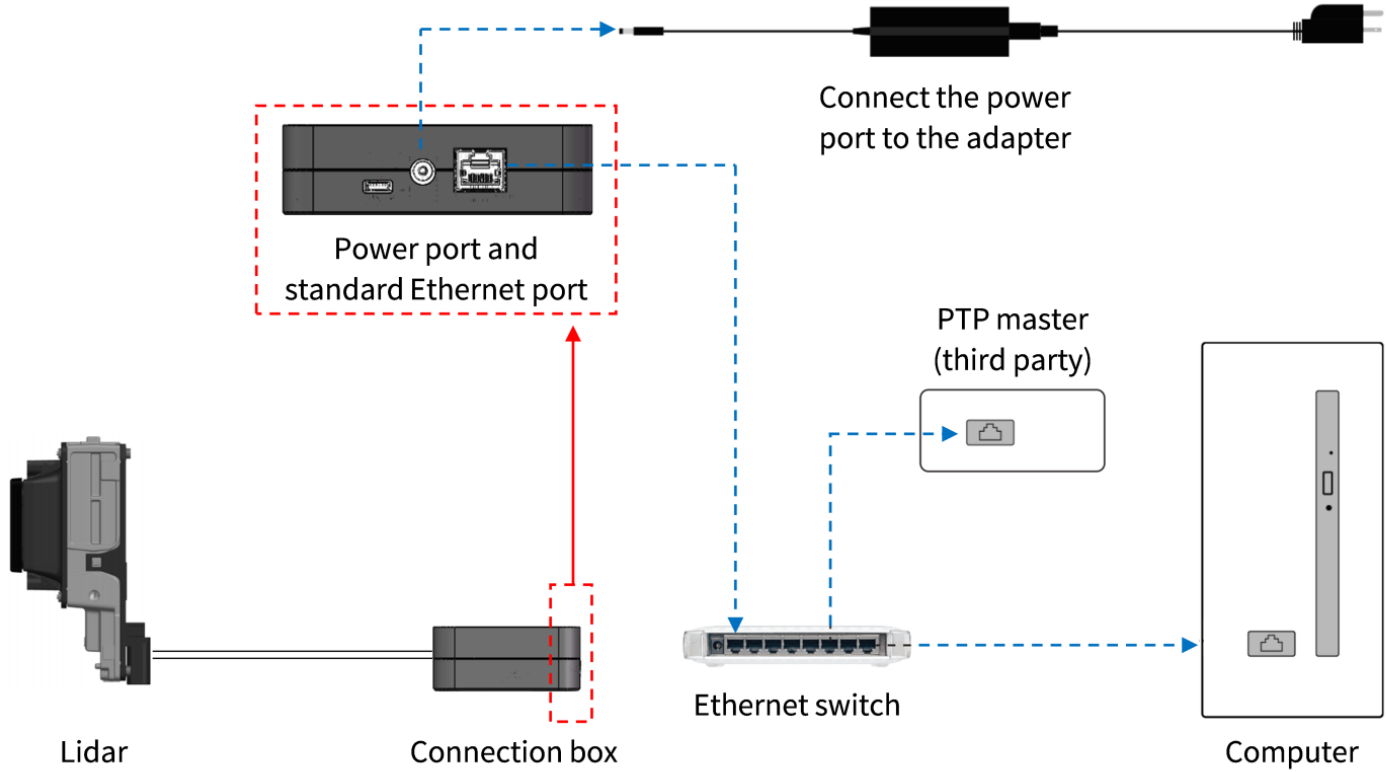

Figure 17. Connection with PTP (hardware device)

2.4. Network settings on the receiving host

The lidar does not have a power switch. It starts operating once connected to power and the Ethernet.

To receive data on your PC, set the PC's IP address to 192.168.1.X and the subnet mask to 255.255.255.0.

 Range of X: 0 to 255 (except 201, 1 and 255)

Ubuntu	Windows
<ol style="list-style-type: none"> 1. Open the terminal. 2. Input this ifconfig command in the terminal: <pre>~\$ sudo ifconfig enp0s20f0u2 192.168.1.X</pre> (replace enp0s20f0u2 with the local Ethernet port name.) 	<ol style="list-style-type: none"> 1. Go to the "Control Panel". 2. Click "Network and Internet" > "Network and Sharing Center" > "Change adapter settings". 3. Right-click the "Ethernet" interface and select "Properties". 4. Double-click "Internet Protocol Version 4 (TCP/IPv4)". 5. Select "Use the following IP addresses" > Configure the IP address to 192.168.1.X and the subnet mask to 255.255.255.0.

2.5. Tools

Tool	Purpose	Where to find it
PandarView 2 (point cloud visualization software)	To record and display point cloud data.	Visit the Download page of Hesai's official website or contact Hesai technical support.
API	To set parameters, check device info or upgrade firmware/software.  <ul style="list-style-type: none"> • Default Source IPv4 address: 192.168.1.201 • Default PTC port: 9347 	Please contact Hesai technical support.

3. Data structure

Unless otherwise specified, all the multi-byte fields are unsigned values in little-endian format.

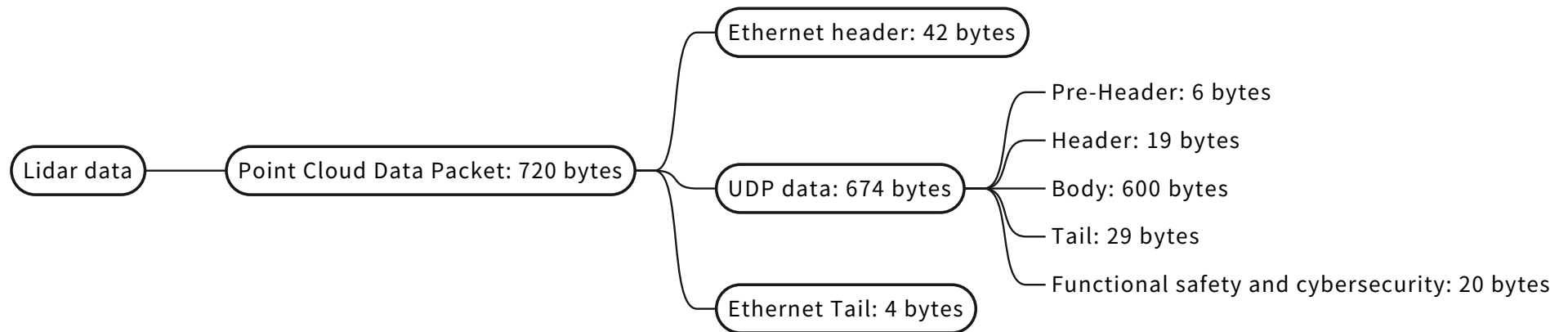

Figure 18. Data structure

3.1. Point Cloud Data Packet

3.1.1. Ethernet header

Default IP address:

Source IP	192.168.1.201
Destination IP	255.255.255.255

Point Cloud Data Packet: Ethernet header

Field	Byte(s)	Description
Ethernet II MAC	12	Destination MAC: xx:xx:xx:xx:xx:xx (FF:FF:FF:FF:FF:FF for broadcast) Source MAC: xx:xx:xx:xx:xx:xx
Ethernet Data Packet Type	2	0x08, 0x00
Internet Protocol	20	Protocol parameters
UDP Port Number	4	Source port (default: 10000) Destination port (default: 2368)
UDP Length	2	Eight bytes more than point cloud UDP data (see Figure 18 , “Data structure”).
UDP Checksum	2	Checksum of the Ethernet header

3.1.2. Point cloud UDP data

3.1.2.1. Pre-Header

Field	Byte(s)	Description
0xEE	1	Start of Packet
0xFF	1	Start of Packet
Protocol Version Major	1	Main class of the point cloud UDP packet structure Current value: 0x07
Protocol Version Minor	1	Subclass of the point cloud UDP packet structure Current value: 0x02
Reserved	2	-

3.1.2.2. Header

Field	Byte(s)	Description
Total Column Number	2	Number of column channels in each frame Point Cloud Data 0xA0 (160)
Total Row Number	2	Number of row channels in each frame Point Cloud Data 0x78 (120)
Column Resolution	1	Design value of horizontal resolution (0.625°) Unit: 0.01° Fixed: 63
Row Resolution	1	Design value of vertical resolution (0.625°) Unit: 0.01° Fixed: 63

Field	Byte(s)	Description
First Block Return	1	<p>Indicating the return in the first block of this packet.</p> <p>0x00 — Single Return mode 0x01 — Dual Return mode: The first block stores the No. 1 return of this return mode. 0x02 — Dual Return mode: The first block stores the No. 2 return of this return mode.</p> <p>For example, if the First Block Return field is 0x02 and the Return Mode field is 0x3C (Dual Return – First and Strongest), then the first block in this packet stores the strongest return of a firing.</p>
Dis Unit	1	<p>Unit of the Distance field in Section 3.1.2.3, Body. Default: 0x04 (4 mm)</p>
Reserved 1	1	-
Channel Number	2	<p>Number of rows in each block 0x78 (120)</p>
Reserved 2	8	-



3.1.2.3. Body



Field	Byte(s)	Description
Block 1: Channel 1	5	<p>Measurements of Column (Column ID + 1), Row 1</p> <p> <ul style="list-style-type: none"> • Data format: See Each row. • Column ID field: See Section 3.1.2.4, Tail. </p>
Block 1: Channel 2	5	Measurements of Column (Column ID + 1), Row 2
...
Block 1: Channel 120	5	Measurements of Column (Column ID + 1), Row 120

Each row

Field	Byte(s)	Description		
Block 1: Channel X	5	Field	Bytes	Description
		Distance	2	Object distance = Distance × Dis Unit  Dis Unit is specified in Section 3.1.2.2, Header .
		Reflectivity	1	Reflectivity = Reflectivity × 1% Range: 0 to 255
		Reserved	2	-

3.1.2.4. Tail

Field	Byte(s)	Description
Reserved	7	-
Column ID	2	Column number = Column ID + 1 Range: 0 to 159  Both row numbers and column numbers count from 1.
Frame ID	1	Rolling counter of frames 0 to 255; increments by 1. Reset to 0 at every start-up.  Each Point Cloud Data Packet stores one return from one column, and thus:  In Single Return mode, each frame is stored in 160 packets.

Field	Byte(s)	Description				
Reserved	1	-				
Return Mode	1	0x37 — Strongest (default) 0x33 — First 0x3C — First and Strongest  Only the Single Return (Strongest) mode is recommended for this version.				
Frame Period	2	100 ms @ 10 Hz Unit: ms				
Date & Time	6	The whole second part of the Coordinated Universal Time (UTC) of this data packet. In big-endian format: <table border="1" data-bbox="757 774 2069 890"> <tr> <td>Byte 1</td> <td>Fixed: 0x00</td> </tr> <tr> <td>Byte 2 to 6</td> <td>Number of seconds since the Unix epoch (1970-01-01 00:00:00 UTC)</td> </tr> </table>	Byte 1	Fixed: 0x00	Byte 2 to 6	Number of seconds since the Unix epoch (1970-01-01 00:00:00 UTC)
Byte 1	Fixed: 0x00					
Byte 2 to 6	Number of seconds since the Unix epoch (1970-01-01 00:00:00 UTC)					
Timestamp	4	The microsecond part of the Coordinated Universal Time (UTC) of this data packet. Unit: μ s Range: 0 to 999 999 μ s  To see the definition of absolute time, please refer to Appendix B, Absolute time of point cloud data .				
Factory Information	1	Fixed: 0x42				
UDP Sequence	4	Sequence number of this data packet Range: 0 to 0xFF FF FF FF				

3.1.2.5. Functional safety and cybersecurity

Field	Byte(s)	Description
CRC	4	CRC-32 checksum from Pre-Header to Tail
Signature	16	<p>Point cloud signature</p> <p>Calculated using point cloud UDP data (from Pre-Header to the CRC field)</p> <p>Algorithm: AES-128-CMAC</p> <p> This field is all zero by default. After users specify a Shared Secret Key and start a session, this field will output a point cloud signature.</p>

3.1.3. Ethernet tail

Field	Byte(s)	Description
FCS	4	Frame check sequence

3.1.4. Point cloud data analysis method

Take **Row 5** in a Point Cloud Data Packet as an example.

 Both row numbers and column numbers count from 1.

3.1.4.1. Analyze the vertical angle and horizontal angle of a data point.

1. Retrieve the angle correction file of this lidar (see [Appendix C, Angle correction](#)).
2. Analyze the **Column ID** field in the Tail; the corresponding column number of this packet is Column ID + 1.
3. Check **Elevation_Adjust[Column ID][4]** and **Azimuth_Adjust[Column ID][4]** in the angle correction file, which are the vertical and horizontal angles of the data point.

3.1.4.2. Analyze the distance of a data point.

See the **Distance** field of **Block 1: Channel 5** in [Section 3.1.2.3, Body](#).

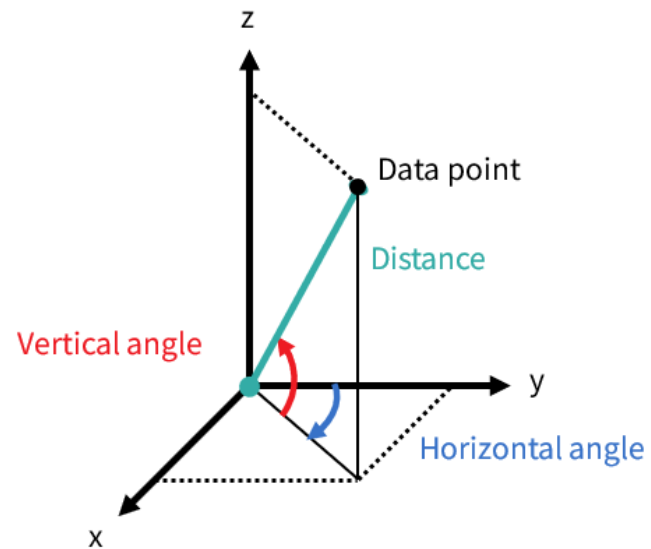
3.1.4.3. Draw the data point in a spherical or rectangular coordinate system.**3.1.4.4. Obtain the real-time point cloud data by analyzing and drawing every data point in each frame**

4. Parameter interfaces

All the parameters in this section can be accessed using API.

4.1. Internet connection

4.1.1. Source

Source IPv4 Address

Option(s)	Description
Default: 192.168.1.201	Applies to both UDP and PTC ports.



Source IPv4 Subnet Mask

Option(s)	Description
Default: 255.255.255.0	Applies to both UDP and PTC ports.

Source IPv4 Gateway

Option(s)	Description
Default: 192.168.1.1	Applies to both UDP and PTC ports.

VLAN

Option(s)	Description
OFF (default) VLAN ID: 1 to 4094	<p>To enable VLAN tagging, use the same VLAN ID on both the lidar and the receiving host.</p> <p> Connection cannot be made if the lidar and the receiving host use different VLAN IDs.</p> <p> <ul style="list-style-type: none"> • Once configured, VLAN ID will not change during firmware upgrades. • When VLAN is enabled, PTP connection will be lost; when VLAN is disabled, PTP connection will automatically recover. </p>

4.1.2. Destination**Destination IPv4 Address**

Option(s)	Description								
Any except 0.0.0.0, 127.0.0.1, and the lidar's IPv4 address Default: 255.255.255.255	<p>Destination IPv4 address</p> <table border="1"> <thead> <tr> <th>Communication mode</th> <th>Destination IP</th> </tr> </thead> <tbody> <tr> <td>Broadcast (default)</td> <td>255.255.255.255</td> </tr> <tr> <td>Multicast</td> <td>User-defined</td> </tr> <tr> <td>Unicast</td> <td>The same as the PC's IPv4 address</td> </tr> </tbody> </table>	Communication mode	Destination IP	Broadcast (default)	255.255.255.255	Multicast	User-defined	Unicast	The same as the PC's IPv4 address
Communication mode	Destination IP								
Broadcast (default)	255.255.255.255								
Multicast	User-defined								
Unicast	The same as the PC's IPv4 address								

Destination Point Cloud UDP Port

Option(s)	Description
Default: 2368	Destination port for Point Cloud Data Packets

Destination Fault Message UDP Port

Option(s)	Description
Default: 2368	Destination port for Fault Message Packets

4.2. Functional settings

Freeze frames

Option(s)	Description
Get freeze frames	A freeze frame records the lidar's status information when a fault occurs and is used in diagnostic analysis.

Functional safety diagnostics switch

Option(s)	Description
ON (default) OFF	<p>When ON, the lidar outputs Fault Message Packets and freeze frames.</p> <ul style="list-style-type: none"> • Fault Message Packets are described in the Safety Manual. Please contact Hesai technical support for more information. • Freeze frames: See Freeze Frames in this section.

Return Mode

Option(s)	Description
Single Return: <ul style="list-style-type: none"> • First • Strongest (default) Dual Return: <ul style="list-style-type: none"> • First and Strongest 	<p>The current return mode is shown in Point Cloud Data Packets; see the Return Mode field in Section 3.1.2.4, Tail.</p> <ul style="list-style-type: none"> • Only the Single Return (Strongest) mode is recommended for this version.

Sync Angle

Option(s)	Description
Function: OFF (default), ON Sync angle: 40° to 139°	<p>After enabling this function and specifying a sync angle (i.e., an azimuth), the lidar will rotate to that azimuthal position at the beginning of every full second.</p> <p> Lidar azimuthal position is defined in Section 1.3, Basic structure.</p> <p>Definition of the full second (detailed in Section B.1, Source of absolute time):</p> <ul style="list-style-type: none"> • When PTP is tracking or locked, the full second is retrieved from the PTP signal. (PPS signal is not required nor used.) • When PTP is frozen or in free run, the full second is defined as the rising edge of the lidar's internal 1 Hz signal. <p>To phase-lock multiple lidar units, connect them to the same clock source and set the same sync angle. These lidar units will rotate to the same azimuthal position at every full second.</p>

4.3. State settings

Restart

Option(s)	Description
Restart	Afterward, the Start-Up Times in Section 4.6, Operation statistics increments by 1.

Sleep

Option(s)	Description
Sleep Wake-Up (by hardware)	<p>In Sleep mode:</p> <ul style="list-style-type: none"> • The lasers stop firing. • No communication exists between the lidar and other devices. • Power consumption is approximately 30 mW. • The time when the lidar is waked up is also recorded as the start-up time; the Start-Up Times in Section 4.6, Operation statistics increments by 1.

To enter Sleep mode

Use the PTC command 0xAB; see TCP API Reference Manual.

- When the PTC command's Return Code = 0x00, the vehicle's domain controller should switch its PHY to Slave mode.
- If Return Code = 0x01, the lidar has failed to enter Sleep mode.

To enter Wake-Up mode

The lidar can only be waked up by hardware. The vehicle's domain controller should switch its PHY to Master mode.

Requirements for the domain controller PHY

To support the Sleep/Wake-Up modes:

- The domain controller PHY should satisfy this test specification:
OPEN ALLIANCE: Automotive Ethernet ECU Test Specification Layer 1 1000BASE-T1 – Revision 1.0
- The domain controller PHY should satisfy these requirements (as specified in Section 97.5 and Section 97.7 in IEEE Std 802.3bp-2016):

- Send **Send_S** patterns when in Master mode.
- Disable auto-negotiation.
- Support Master-Slave configuration.
- The **Send_S** patterns sent by the domain controller PHY in Master mode should satisfy these requirements:
 - When cable length = 5 m, $V_{pp} > 0.84$ V.
 - When cable length = 15 m, $V_{pp} > 0.92$ V.
- The domain controller PHY in Slave mode should by default NOT send **Send_T** patterns, i.e., the TC10 WUP (wake up pattern) signal.

Standby Mode

Option(s)	Description
In Operation (default) Standby	In Standby mode: <ul style="list-style-type: none"> • The motor stops running and lasers stop firing. • No point cloud output. • The diagnostic functions that are not related to laser firing remain normal.

4.4. Time sync

Read-only parameter	Description	
PTP Status	Free Run	No PTP master is selected.
	Tracking	Attempting to sync with the selected PTP Master, but the absolute offset exceeds the user-specified limit. See PTP Lock Time Offset in this section.
	Locked	The absolute offset is within the user-specified limit.
	Frozen	The lidar has lost connection to the PTP master and is attempting to recover it. Meanwhile, lidar time will drift from the last synchronized time. When the time drift exceeds the specification, PTP status will change to Free Run.

PTP Profile

Option(s)	Description
802.1AS Automotive (default) 802.1AS AUTOSAR	IEEE timing and synchronization standard

PTP Lock Time Offset

Option(s)	Description
1 to 100 μ s (integer) Default: 1	Upper limit of the absolute offset between Slave and Master when the lidar is in PTP Locked status. See PTP status in this section.

PTP Domain Number

Option(s)	Description
0 to 127 (integer) Default: 0	Domain attribute of the local clock

PTP Network Transport

Option(s)	Description
L2	Network transport protocol

Switch Type

Option(s)	Description				
TSN (default)	Type of the network switch				
Non-TSN	<table border="1"> <tbody> <tr> <td>TSN</td> <td>Time Sensitive Network, using Peer-to-Peer delay mechanism</td> </tr> <tr> <td>Non-TSN</td> <td>Using End-to-End delay mechanism</td> </tr> </tbody> </table>	TSN	Time Sensitive Network, using Peer-to-Peer delay mechanism	Non-TSN	Using End-to-End delay mechanism
TSN	Time Sensitive Network, using Peer-to-Peer delay mechanism				
Non-TSN	Using End-to-End delay mechanism				

4.5. Lidar info

Read-only parameter	Description
SN	Serial Number
PN	Part Number, indicating the lidar's hardware version Format: [Lidar Model]-[Configuration]
MAC address	Media access control (MAC) address Format: XX:XX:XX:XX:XX:XX (hexadecimal)
Lidar Model	FT120

Angle correction file



Option(s)	Description
get file	The angle correction file of each lidar unit is used to correct the azimuth and elevation of each channel.

4.6. Operation statistics

Availability (Read-only parameter)

- Start-Up Times
- System Uptime
- Total Operation Time

Functional safety

Read-only parameter	Description	
Work mode	Work mode	Description
	Energy-Saving	Laser power is 1/20 of that in Standard mode; no point cloud output.  The lidar enters this mode when an eye safety fault is detected.
	Standard	Default
	Standby	See Standby Mode .  Users decide whether to enter or exit the Standby mode.
	High-Temp-Shutdown	The lidar stops working; can return to Normal.
	Other-Fault-Shutdown	The lidar stops working; cannot return to Normal.
	Fault code	Indicates whether the lidar is in the following fault states: <ul style="list-style-type: none"> • Performance degradation (from Standard to Energy-Saving) • High-temperature shutdown • Other shutdown

4.7. Upgrade

Upgrade

Option(s)	Description
Upgrade	Upgrade the lidar's firmware and software.

5. Communication protocol

Pandar TCP Commands (PTC) API can be used to communicate with Hesai lidars.

 To acquire the API reference manuals, please contact Hesai technical support.

6. Maintenance

The lidar's optical window is made of plastic (polycarbonate, PC), similar to the material used for car lamps.

- Do NOT wipe the optical window when it is dry, nor use abrasive cleaners. Doing so can damage the optical coating.
- Do NOT use organic cleaners, which can damage the optical window and even cause cracking.
 - Organic cleaners include but are not limited to tar cleaners, self-cleaning agents, adhesive removers, coating removers, foam cleaners, paint mist removers, glass cleaners, thinning agents, de-icers, paint surface treatment agents, alcohol, and vinegar.
 - Do NOT use automatic car wash equipment to clean the lidar. Before washing the car or performing related operations, protect the optical window to prevent any contact with organic cleaners.
-  • Do NOT apply excessive force to the lidar, as this can damage the optical window.
- If a pressure washer is used to clean the optical window, make sure the distance between the nozzle and the optical window remains at least 60 cm.
- After prolonged exposure to strong sunlight and high temperatures, the optical window should NOT be cleaned immediately.
- If snow or ice accumulates on the optical window, do NOT use a pressure washer or ice scraper.
 - A small broom is recommended to remove snow.
 - A solvent-free (i.e., free of organic solvents) ice removal spray is recommended to remove ice; alternatively, wait for the ice to melt by itself.
- Do NOT wax the optical window.

 Please regularly check the optical window, considering your car use frequency, parking environment, and climate conditions.

- If foreign objects (such as dust, fingerprints, or oil stains) are found on the optical window, make sure to clean it.
- If corrosive foreign objects (such as insect remains, bird droppings, tree resin, road dust, industrial dust, asphalt, soot particles, and road salt) are found on the optical window, make sure to clean it immediately.

Cleaning procedure

1. Make sure the lidar is powered OFF.
2. Choose a cleaning agent:
 - For light stains, use room temperature water.
 - For heavier stains, use a mild soap solution (no more than two tablespoons of soap per quart or liter of water).
 - For stubborn stains, use a solvent-free (i.e., free of organic solvents), neutral detergent at room temperature, such as car shampoo.
3. Take a clean soft sponge or anti-static microfiber cloth, dampen it with the chosen cleaning agent, and gently wipe the dirty area on the optical window back and forth.
4. For stubborn stains, cover the dirty area with the dampened sponge or cloth to soften the stains before wiping.
5. Immediately after removing the stains, rinse the optical window with clean water. Then use a clean soft sponge or microfiber cloth to gently wipe away any remaining liquid (which may contain residual cleaning agent or contaminants).

7. Troubleshooting

If the following procedures cannot solve your problem, please contact Hesai technical support.

Symptoms	Points to check
Indicator light is off on the connection box.	<p>Make sure that the following conditions are met:</p> <ul style="list-style-type: none">• The power adapter is properly connected and in good condition.• The connection box is intact.• The input voltage and input current satisfy the requirements in Section 2.3, Connection box (optional). <p>Afterward, power on the lidar again and check if the symptom persists.</p>
Output data can be received by Wireshark but not by PandarView 2.	<p>Make sure that the following conditions are met:</p> <ul style="list-style-type: none">• Lidar Destination Port is correctly set; this can be confirmed using PTC commands.• If VLAN is enabled, the PC's VLAN ID should be the same as the lidar's; this can be checked using PTC commands.• The PC's firewall is disabled, or PandarView 2 is added to the firewall exceptions.• The latest PandarView 2 is installed (see Downloads page of Hesai's official website or contact Hesai technical support). <p>Afterward, power on the lidar again and check if the symptom persists.</p>

Symptoms	Points to check
<p>The point cloud is abnormal, showing obviously misaligned points, flashing points, or incomplete FOV.</p>	<p>Make sure that the following conditions are met:</p> <ul style="list-style-type: none"> • The lidar's optical window is clean. If not, refer to Section 6, Maintenance for the cleaning method. • The lidar's angle correction file is imported (refer to PandarView 2 User Manual). • The lidar's internal temperature is between -40°C and 110°C; this can be confirmed using PandarView 2 or PTC commands. <p>Afterward, check for packet loss.</p> <p>If no packet is lost yet the point cloud flashes, please follow the steps below:</p> <ol style="list-style-type: none"> 1. Update PandarView 2 to the latest version (see Downloads page of Hesai's official website or contact Hesai technical support). 2. Restart the PC. <p>If the point cloud is still abnormal, follow the steps below:</p> <ol style="list-style-type: none"> 1. Connect the lidar to another PC and another network. 2. Power on again and check if the symptom persists.
<p>The number of data packets received is abnormal, indicating missing packets.</p>	<p>Make sure that the following conditions are met:</p> <ul style="list-style-type: none"> • The lidar's internal temperature is between -40°C and 110°C; this can be confirmed using PandarView 2 or PTC commands. • Ethernet is not overloaded. • No switch is connected to the network (the data transmitted from other devices may cause network congestion and packet loss). <p>Afterward, follow the steps below:</p> <ol style="list-style-type: none"> 1. Connect the PC to no other devices but the lidar and check for packet loss. 2. Power on the lidar again and check if the symptom persists.

Appendix A: Performance distribution

Considering the characteristics of the lidar optical system and the performance requirements of different application scenarios, the distribution of ranging capability among row/column channels is designed as follows.

i The optimal performance of a channel is defined as 100%.

		Column ID																
		1	10	20	30	40	50	60	70	80	90	100	110	120	130	140	150	160
Row ID	120	30%	33%	33%	38%	41%	39%	42%	42%	38%	42%	41%	39%	41%	38%	33%	33%	27%
	110	34%	35%	36%	41%	43%	40%	44%	44%	40%	44%	44%	40%	43%	41%	36%	36%	31%
	100	41%	42%	40%	46%	47%	43%	48%	48%	44%	49%	47%	43%	48%	45%	40%	42%	37%
	90	51%	51%	47%	53%	54%	49%	54%	55%	49%	55%	54%	49%	54%	52%	47%	52%	46%
	80	67%	68%	62%	68%	71%	63%	71%	71%	64%	72%	70%	64%	72%	69%	62%	68%	61%
	70	87%	89%	83%	93%	97%	88%	98%	99%	90%	99%	97%	88%	98%	92%	83%	89%	80%
	60	91%	95%	88%	99%	99%	96%	99%	99%	99%	99%	99%	96%	99%	99%	88%	96%	83%
	50	88%	89%	83%	93%	98%	88%	98%	99%	90%	99%	97%	88%	98%	93%	83%	90%	79%
	40	67%	68%	62%	69%	71%	64%	70%	71%	64%	72%	70%	63%	71%	68%	62%	69%	61%
	30	51%	51%	47%	52%	54%	49%	54%	55%	49%	55%	54%	49%	55%	52%	47%	51%	46%
	20	41%	42%	40%	46%	47%	43%	48%	49%	44%	48%	48%	43%	48%	45%	40%	42%	36%
	10	34%	36%	36%	41%	42%	40%	44%	44%	40%	44%	43%	40%	43%	40%	36%	36%	31%
1	30%	32%	33%	38%	41%	39%	42%	42%	39%	43%	42%	38%	41%	38%	33%	33%	27%	

Appendix B: Absolute time of point cloud data

B.1. Source of absolute time

The lidar retrieves the current absolute time by connecting to an external clock source.

B.1.1. PTP as the clock source

The lidar connects to a third-party PTP master to obtain PTP signal.



- PPS signal is not required nor used.
- PTP can be configured using PTC commands.
- The status of PTP signal can be found using PTC commands.

The absolute time is updated as follows:

PTP status	Date and time (accurate to the microsecond)	Lidar behavior
Free run	Virtual	Since the lidar has not been locked before, it starts counting from a virtual UTC (such as 1970-01-01 00:00:05) using the lidar's internal 1 Hz signal.
Tracking or Locked	Synchronized	The lidar extracts the actual date and time from the PTP Master's messages.
Frozen	Drifting	When the lidar goes from Tracking/Locked to Frozen, it starts counting from the last synchronized time using the lidar's internal 1 Hz signal. This absolute time will gradually drift from the actual PTP time.



- PTP is a Plug & Play protocol; the lidar works as a PTP slave device and requires no additional setup.
- The **Timestamps** and **Date & Time** fields in Point Cloud Data Packets strictly follow the PTP master device. Certain PTP master devices may have a specified offset from the lidar's time output. Please verify the configuration and calibration of your PTP master device.

B.2. Absolute time of Point Cloud Data Packets

The absolute time of Point Cloud Data Packets is $t_0 = t_s + t_{ms}$, where:

- t_s is the whole second part (see the **Date & Time** field).
- t_{ms} is the microsecond part (see the **Timestamp** field).

The definition of the above fields is in [Section 3.1.2.4, Tail](#).

Appendix C: Angle correction

Each lidar unit corresponds to an angle correction file, which contains the corrections of horizontal angles (azimuth) and vertical angles (elevation). Such corrections are used for:

- Point cloud data analysis
- Point cloud display in PandarView 2

Angle correction file

In case you need to obtain this file again, please do one of the following:

- Send PTC command 0x05, as described in the TCP API Reference Manual (see [Section 5, Communication protocol](#)).
- Export the file using PandarView 2 according to PandarView 2 user manual.
- Contact sales representatives or technical support.

Notes



- The angle correction file is a .dat file. Please use a hex viewer/editor to check it.
- Byte size of the file: $8 \times M \times N + 41$

C.1. Data format

Unless otherwise specified, all the multi-byte fields are in little-endian format.

Field	Byte(s)	Type	Description
0xEE	1	uint	Start of Packet
0xFF	1	uint	Start of Packet

Field	Byte(s)	Type	Description
Protocol Version Major	1	uint	Main class of the angle correction data structure Currently 0x02
Protocol Version Minor	1	uint	Subclass of the point cloud UDP packet structure Currently 0x01
Reserved	2	-	-
Total Column Number	2	uint	Number of column channels in each frame of Point Cloud Data, denoted as M. 0xA0 (160)
Total Row Number	2	uint	Number of row channels in each frame of Point Cloud Data, denoted as N. 0x78 (120)
Resolution	1	uint	Used in the units of the following fields. Every 0x01 stands for 1°. For example: 0x01 stands for 1° and 0x02 stands for 2°.
Azimuth_Adjust[0 : M*N-1]	4 × M × N	int32 array	Corrected azimuth, 4 bytes each. Format: 2D array A[M][N] <ul style="list-style-type: none"> • M rows correspond to Column Channels 1 to 160. • N columns correspond to Row Channels 1 to 120. • Output in column-major order. Unit: Resolution
Elevation_Adjust[0 : M*N-1]	4 × M × N	int32 array	Corrected elevation, 4 bytes each. Format: 2D array E[M][N] (with the same format as Azimuth_Adjust) Unit: Resolution

Field	Byte(s)	Type	Description
SHA-256 Value	32	uint	SHA-256 hash of this angle correction file

Appendix D: Legal notice

Copyright © 2017-2024 Hesai Technology Co., Ltd.

All rights reserved. Use or reproduction of this manual in parts or in its entirety without the authorization of Hesai is prohibited.

Hesai Technology makes no representations or warranties, either expressed or implied, with respect to the contents hereof and specifically disclaims any warranties, merchantability, or fitness for any particular purpose. Further, Hesai Technology reserves the right to revise this publication and to make changes from time to time in the contents hereof without obligation to notify any person of such revisions or changes.

HESAI and HESAI logo are registered trademarks of Hesai Technology. All other trademarks, service marks, and company names in this manual or on Hesai's official website are properties of their respective owners.

The software included in this product contains the copyright that is registered under Hesai Technology. Any third party is not permitted, except as expressly permitted by the licensor or expressly required by applicable law, to decompile, reverse engineer, disassemble, modify, rent, lease, loan, distribute, sublicense, create derivative works based on the whole or any part of the software.

Hesai Product Warranty Service Manual is on the Warranty Policy page of Hesai's official website: <https://www.hesaitech.com/warranty-policy/>

Hesai Technology Co., Ltd.

Phone: +86 400 805 1233

Website: www.hesaitech.com

Address: Building A, Haisu Culture Plaza, Shanghai, China

Business Email: info@hesaitech.com

Service Email: service@hesaitech.com