

# Pandar64

## 64-Channel Mechanical Lidar User Manual

Classification: Public

Doc version: 640-en-241220

# Table of Contents

■ <b>About this manual</b> .....	<b>1</b>
Access to this manual .....	1
Technical support .....	1
Legends and format .....	1
■ <b>Safety notice</b> .....	<b>2</b>
Special warnings .....	2
Operating environment .....	3
Personnel .....	5
Installation and operation .....	5
Repair .....	9
<b>1. Introduction</b> .....	<b>10</b>
1.1. Applicability .....	10
1.2. Operating principle .....	10
1.3. Basic structure .....	11
1.4. Channel distribution .....	13
1.5. Specifications .....	14
<b>2. Setup</b> .....	<b>16</b>
2.1. Mechanical installation .....	16
2.1.1. Exterior dimensions .....	16
2.1.2. Quick installation .....	18
2.1.3. Stable installation .....	18
2.1.4. Notes on screw installation .....	20
2.2. Electrical interface .....	21
2.2.1. Pin description .....	21
2.2.2. Connector use .....	23

2.2.3. Cables (Ethernet)	24
2.3. Connection box (optional)	25
2.3.1. Ports	26
2.3.2. Connection	29
2.4. Network settings on the receiving host	31
2.4.1. In Windows	32
2.4.2. In Ubuntu	35
2.5. Tools	38
<b>3. Data structure</b>	<b>39</b>
3.1. Point Cloud Data Packet	40
3.1.1. Ethernet header	40
3.1.2. Point cloud UDP data	41
3.1.3. Ethernet tail	45
3.1.4. Point cloud data analysis method	46
3.2. GPS Data Packet	49
3.2.1. Ethernet header	49
3.2.2. GPS UDP data	50
3.2.3. Ethernet tail	53
3.2.4. GPS time data analysis method	54
<b>4. Web Control</b>	<b>55</b>
4.1. Home	56
4.2. Settings	58
4.2.1. Network	60
4.2.2. Function	61
4.2.3. Time sync	64
4.3. Azimuth FOV	67
4.3.1. For all channels	68

4.3.2. For each channel	68
4.3.3. Multi-section FOV	69
4.4. Operation statistics	70
4.5. Upgrade	71
<b>5. Maintenance</b>	<b>72</b>
<b>6. Troubleshooting</b>	<b>74</b>
<b>Appendix A: Channel distribution data</b>	<b>78</b>
<b>Appendix B: Absolute time of point cloud data</b>	<b>83</b>
B.1. Source of absolute time	83
B.1.1. GPS as the clock source	83
B.1.2. PTP as the clock source	84
B.2. Absolute time of the Point Cloud Data Packets	86
B.3. End time of each block	86
B.4. Laser firing time of each channel	87
<b>Appendix C: Phoenix connector</b>	<b>91</b>
<b>Appendix D: Nonlinear reflectivity mapping</b>	<b>93</b>
<b>Appendix E: Legal notice</b>	<b>98</b>

## ■ About this manual

Please make sure to read through this user manual before your first use and follow the instructions herein when you operate the product. Failure to comply with the instructions may result in product damage, property loss, personal injuries, and/or a breach of warranty.

### Access to this manual

To obtain the latest version, please do one of the following:

- Visit the Download page of Hesai's official website: <https://www.hesaitech.com/downloads/>
- Contact your sales representative of Hesai.
- Contact Hesai technical support: [service@hesaitech.com](mailto:service@hesaitech.com)

### Technical support

If your question is not addressed in this user manual, please contact us at:

- [service@hesaitech.com](mailto:service@hesaitech.com)
- <https://www.hesaitech.com/technical-support/>
- <https://github.com/HesaiTechnology>

### Legends and format

 **Warnings:** Instructions that must be followed to ensure safe and proper use of the product.

 **Notes:** Additional information that may be helpful.

Monospace font: field names

For example: **Distance** represents the Distance field.

## ■ Safety notice

- Please make sure to read through this safety notice and follow all the instructions and warnings. Failure to comply with the instructions and warnings may result in product damage, property loss, and/or personal injuries.
- Please check the certification information on the product's nameplate and read through the corresponding certification warnings. If specific users require not presenting certification information on the nameplate, please follow the agreed-to arrangements.
- If you incorporate this lidar product into your product(s), you are required to provide this user manual (or access to this user manual) to the intended users of your product(s).
- This lidar product is intended as a component of an end product. It is the responsibility of the end-product supplier to assess the risk of use in accordance with applicable standards and inform the intended user of safety-related information.
- Should there be other agreements with specific users, the other agreements shall apply.
- Before using a product, please confirm with Hesai the development maturity of the product in a timely manner. For products still in development, Hesai makes no warranty of non-infringement nor assumes any responsibility for quality assurance.

## Special warnings

### Laser safety

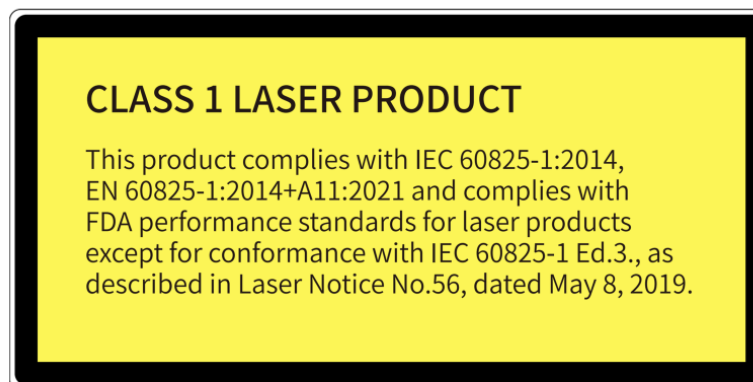

## Hot surface



### Hot parts!

Burned fingers when handling the parts.

Wait one-half hour after switching off before handling the parts.

## Abnormalities

In any of the circumstances listed below, stop using the product immediately:

- If you suspect malfunctions of or damage to the product, with symptoms such as significant noise or visible vibration.
- If you or people in the nearby environment feel discomfort.
- If any device or equipment in the nearby environment malfunctions.

Meanwhile, contact Hesai or an authorized Hesai service provider for more information on product disposal.

## Prohibition of disassembly

Unless expressly agreed to in writing by Hesai, do NOT disassemble the product.

## Operating environment

### Radio frequency (RF) interference

- Before using the product, make sure to read all the signs and notices on the product enclosure (including the nameplate). If specific users require not presenting certification information on the nameplate, please follow the agreed-to arrangements.
- Although the product is designed, tested, and manufactured to comply with the regulations on RF radiation (such as FCC, CE-EMC, or KCC), the radiation from the product may still influence electronic devices.

**Vibration**

- If significant mechanical shocks and vibration exist in the product's operating environment, please contact Hesai's technical support to obtain the shock and vibration limits of your product model. Exposure to over-the-limit shocks or vibration may damage the product.
- Make sure to package the product in shock-proof materials to avoid damage during transport.

**Explosive atmosphere and other air conditions**

- Do NOT use the product in any area where potentially explosive atmospheres are present, such as environments with high concentrations of flammable chemicals, vapors, or particulates (including particles, dust, and metal powder) in the air.
- Do NOT expose the product to environments having high concentrations of industrial chemicals, including liquefied gases that are easily vaporized (such as helium). Such exposure can damage or impair product functionality.

**Chemical environment**

Do NOT expose the product to corrosive or strong polar chemical environments (such as liquids or gases), including but not limited to strong acids, strong bases, esters, and ethers. This is to avoid damage to the product (including but not limited to water resistance failure).

**Ingress protection (IP)**

Please check the product's user manual for its IP rating (refer to [Section 1.5 Specifications](#)). Make sure to avoid any ingress beyond that rating.

**Operating temperature**

Please check the product's user manual for its operating temperature (refer to [Section 1.5 Specifications](#)). Make sure not to exceed the operating temperature range.

**Recommended storage conditions**

Please store the product in a dry and well-ventilated place. The recommended ambient temperature is  $23 \pm 5^{\circ}\text{C}$ , and the humidity is between 30% and 70%.



### **Light interference**

Certain precision optical instruments may interfere with the laser light emitted from the product. Please check all the instructions for these instruments and take preventive measures if necessary. For example, protective leather covers are provided for certain product models; when these lidars are temporarily not used for measurement, the leather covers can be applied to block laser light emission.

## **Personnel**

### **Recommended operator qualifications**

The product should be operated by professionals with engineering backgrounds or experience in operating optical, electrical, and mechanical instruments. Please follow the instructions in this manual when operating the product and contact Hesai technical support if needed.

### **Medical device interference**

- Some components in the product can emit electromagnetic fields. If the product operators or people in the nearby environment wear medical devices (such as cochlear implants, implanted pacemakers, and defibrillators), make sure to consult the physicians and medical device manufacturers for medical advice, such as determining whether keeping the product a safe distance away from the medical devices is needed.
- If you suspect that the product is interfering with your medical device, stop using the product immediately.

## **Installation and operation**

## Power supply

- Before powering on the product, make sure the electrical interfaces are dry and clean. Do NOT power on the product in humid conditions.
- Do NOT use out-of-spec or damaged cables or adapters.
- You are recommended to use only the cables and power adapters provided by Hesai. If you are to design, configure, or select the power supply system (including cables) for the product, make sure to comply with the electrical specifications in the product's user manual (refer to [Section 1.5 Specifications](#) and the Power Supply Requirements section if available); for technical support, please contact Hesai.
- Please check [Section 2.2 Electrical interface](#) and strictly follow the instructions on plugging/unplugging the connector. If abnormalities already exist (such as bent pins, broken cables, and loose screws), stop using the product and contact Hesai technical support.

## Eye safety

The product is a Class 1 laser product. It satisfies the requirements of:

- IEC 60825-1:2014
- EN 60825-1:2014+A11:2021
- 21 CFR 1040.10 and 1040.11 except for deviations (IEC 60825-1 Ed.3) pursuant to Laser Notice No.56, dated May 8, 2019.

**CAUTION:** Use of controls or adjustments or performance of procedures other than those specified herein may result in hazardous radiation exposure.

### CAUTION

- For maximum self-protection, it is strongly warned that users do NOT look into the transmitting laser through a magnifying product (microscope, eye loupe, magnifying glass, etc.).
- This product does not have a power switch. It starts operating once connected to power. During operation, the entire cover lens can be regarded as the product's laser emitting window; looking at the cover lens can be regarded as looking into transmitting laser.

## Product enclosure

- The product contains metal, glass, plastic, as well as sensitive electronic components. If the product is dropped or burnt, stop using it immediately and contact Hesai technical support.
- Do NOT squeeze or pierce the product. If the product enclosure is broken, stop using it immediately and contact Hesai technical support.
- Certain product models contain high-speed rotating parts. To avoid potential injuries, do NOT operate the product if the enclosure is loose.
- If the product enclosure consists of fins or grooves, please wear gloves when handling the product. Applying too much pressure with your bare hands may cause cuts, bruises or other injuries.

## Cover lens

 The location of the cover lens is illustrated in [Section 1 Introduction](#).

- Do NOT apply protective film, wax or any other substance on the cover lens.
- To keep the product's cover lens from fingerprints and other stains, do NOT touch the cover lens with bare hands. If the cover lens is already stained, please refer to the cleaning method in [Section 5 Maintenance](#).
- To prevent scratches, do NOT touch the product's cover lens with hard or sharp objects. If scratches already exist, stop using the product and contact Hesai technical support. Severe scratches may affect the quality of the product's point cloud data.

## Mounting

- Before operating the product, make sure it is properly and securely mounted. The mounting should prevent the product from leaving its mounting position under external forces (such as collisions, high winds, and stone impacts).
- Before installing any exterior part, please ensure that each exterior part and its movable area do not overlap the Field of View (FOV) of the lidar.

 The FOV of lidar is the spatial angular range bounded by the horizontal and vertical FOV ranges (see [Section 1.5 Specifications](#)); the distance to the origin of the lidar's coordinate system is not limited. For inquiries about the FOV, please contact Hesai technical support.

### **Hot surface**

During operation or the time period after the operation, the product's enclosure can be hot.

- To prevent discomfort or even burns, do NOT touch the product's enclosure with your skin.
- To prevent fires, make sure to keep flammable materials away from the product's enclosure.

Certain product models support active heating of the cover lens to reduce the impact of ice and frost.

- While active heating is ON, please avoid direct skin contact with the cover lens.
- Users can turn off active heating.

### **Peripherals**

The product may be used along with accessories and devices, such as suction cup mounts, extension cables, power supplies, network devices, GPS/PTP devices, CAN transceivers, and cleaning equipment.

When selecting a peripheral, please refer to all relevant specifications in the product's user manual or contact Hesai technical support. Using out-of-spec or unsuitable devices may result in product damage or even personal injuries.

### **Firmware and software upgrading**

Make sure to use only the upgrade files provided by Hesai. Make sure to observe all the instructions provided for that upgrade file.

### **Customized firmware and software**

- Before using a customized version of firmware and software, please fully understand the differences in functions and performance between the customized version and the standard version.
- Make sure to strictly follow all the instructions and safety precautions provided for that customized version. If the product does not function as anticipated, stop using the product immediately and contact Hesai technical support.

### Point cloud data processing

- Certain product models support one or more point cloud data processing functions, including but not limited to: Noise Filtering, Interstitial Points Filtering, Retro Multi-Reflection Filtering, and Non-Linear Reflectivity Mapping.
- These functions are configurable and are intended only to assist the user in extracting information from the point cloud data. Users are in full control of whether to use any of these functions. Moreover, users are responsible for analyzing the product's intended application scenarios and evaluating the risk of enabling one or more of these functions in combination.
- To learn about the supported functions of a product model, please contact Hesai technical support.

## Repair

- Unless expressly agreed to in writing by Hesai, do NOT disassemble, repair, modify, or retrofit the product by yourself or entrust any third party to do so. Such a breach:
  - can result in product damage (including but not limited to water resistance failure), property loss, and/or injuries;
  - shall constitute a breach of warranty.
- For more product repair issues, please contact Hesai or an authorized Hesai service provider.

# 1. Introduction

## 1.1. Applicability

This manual applies to the following versions:

Software	2.10.8 or later
Firmware of Sensor	4.3.44b or later
Firmware of Controller	5.32 or later

## 1.2. Operating principle

Distance measurement: Time of Flight (ToF)

1. A laser diode emits a beam of ultrashort laser pulses onto the target object.
2. The laser pulses are reflected after hitting the target object. The returning beam is detected by an optical sensor.
3. Distance to the object can be accurately measured by calculating the time between laser emission and receipt.

$$d = \frac{ct}{2}$$

d: Distance

c: Speed of light

t: Travel time of the laser beam

## 1.3. Basic structure

The basic structure is shown below.

64 pairs of laser emitters and receivers are attached to a motor that rotates 360° horizontally.

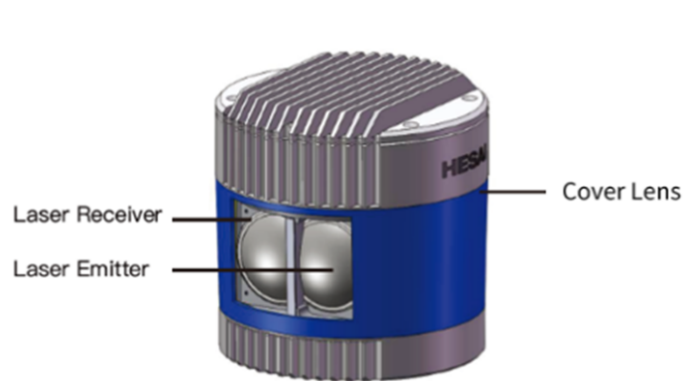

Figure 1. Partial cross-sectional diagram

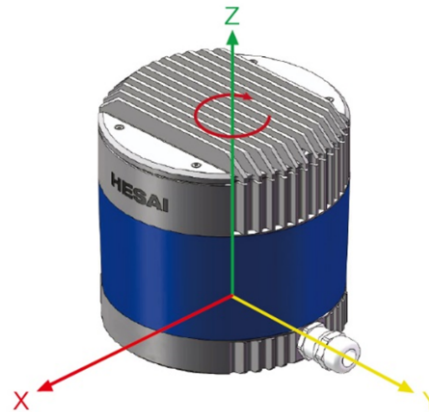

Figure 2. Coordinate system (isometric view)

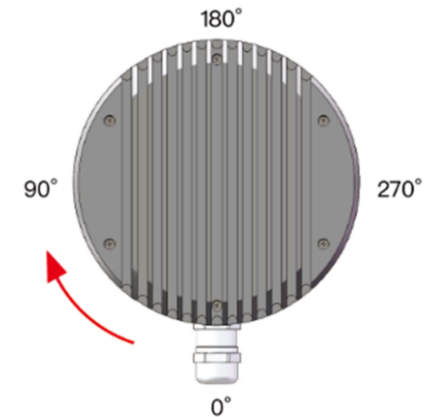

Figure 3. Rotation direction (top view)

The lidar's coordinate system is illustrated in [Figure 2](#).

- Z-axis is the axis of rotation.
- The origin is shown as a red dot in [Figure 5](#). All measurements are relative to the origin.

The lidar azimuthal position is defined in [Figure 3](#).

- Y-axis corresponds to 0°.
- Each laser channel has an intrinsic azimuth offset. **Channel 18** is selected to define the lidar's azimuthal position.

For example, when **Channel 18** passes the 90° position:

- the lidar is at the 90° position;

- the azimuth of the corresponding data block in the Point Cloud Data Packet is 90°.



## 1.4. Channel distribution

All channels are unevenly distributed, as illustrated in [Figure 4](#).

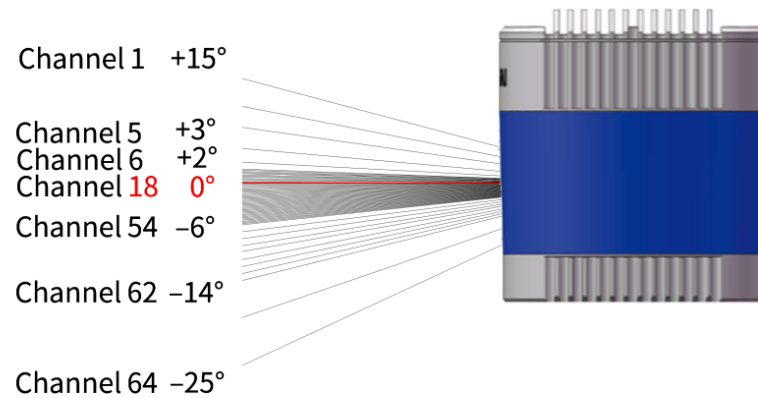

Figure 4. Channel vertical distribution

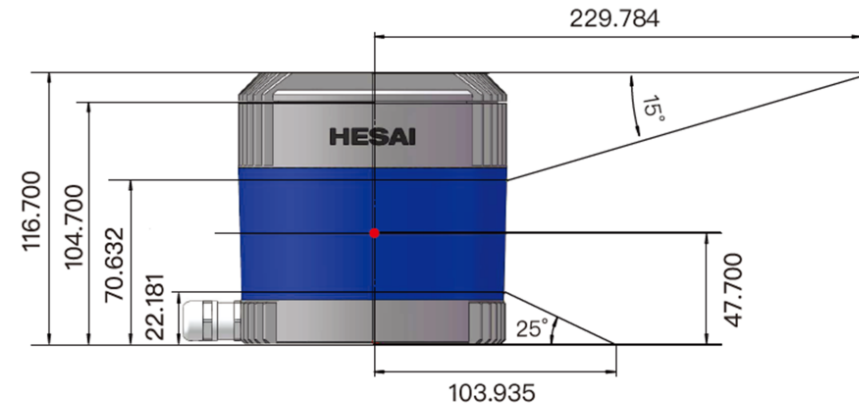

Figure 5. Laser firing position (unit: mm)

Each channel has an intrinsic angle offset, both horizontally and vertically. These angles are recorded in the angle correction file of this lidar, which is provided when shipping.

### Angle correction file

In case you need to obtain this file again, please do one of the following:

- Send PTC command 0x05, as described in the *TCP API Reference Manual*.
- Export the file using PandarView 2 according to *PandarView 2 User Manual*.
- Contact sales representatives or technical support.

## 1.5. Specifications

### SENSOR

Scanning method	Mechanical rotation
Number of channels	64
Ranging capability	0.3 to 200 m (at 10% reflectivity)
Ranging accuracy ①	±5 cm (0.3 to 1 m), ±2 cm (1 to 200 m)
Horizontal FOV	360°
Horizontal resolution	0.2° (10 Hz), 0.4° (20 Hz)
Vertical FOV	40° (-25° to +15°)
Vertical resolution	0.167° (Channels 6 to 54) 1° (Channels 5 to 6, 54 to 62)
Frame rate	10 Hz, 20 Hz
Return mode	Single Return: Last/Strongest Dual Return: Last and Strongest

### MECHANICAL/ELECTRICAL/OPERATIONAL

Wavelength	905 nm
Laser class	Class 1 Eye Safe
Ingress protection	IP6K7
Dimensions	Height: 116.7 mm Top/Bottom: Φ118.0/116.0 mm
Rated voltage range	DC 9 to 48 V

Power consumption ②	22 W (typical)
Operating temperature	-20°C to 65°C
Storage temperature	-40°C to 85°C
Weight	1.52 kg

**DATA I/O**

Data transmission	100BASE-TX, slave mode
Measurements	Distance, azimuth angle, and reflectivity
Valid point rate	<b>Single Return:</b> : 1 152 000 points/sec <b>Dual Return:</b> : 2 304 000 points/sec
Point cloud data rate	<b>Single Return:</b> 29.76 Mbps <b>Dual Return:</b> 59.52 Mbps
Clock source	GPS/PTP (1588v2, 802.1AS, 802.1AS Automotive)
PTP clock accuracy	≤ 1 μs
PTP clock drift ③	≤ 1 μs/s

 Specifications are subject to change. Please refer to the latest version of this manual.

**Notes to specifications**

- ① **Ranging accuracy**
  - Defined as the average range error across all channels.
  - May vary with range, temperature, and target reflectivity.
- ② **Power consumption**
  - Not including accessories such as the connection box.
  - The external power supply should be able to provide at least 22 W.
- ③ **PTP clock drift**
  - Defined as the drift at a constant temperature after the lidar (slave clock) loses connection to the PTP master.

## 2. Setup

Before operating the lidar, strip away the protective cover on the cover lens.



The information in this section may be different for customized models. The mechanical drawings and data exclusively provided for customized models shall prevail.

### 2.1. Mechanical installation

#### 2.1.1. Exterior dimensions

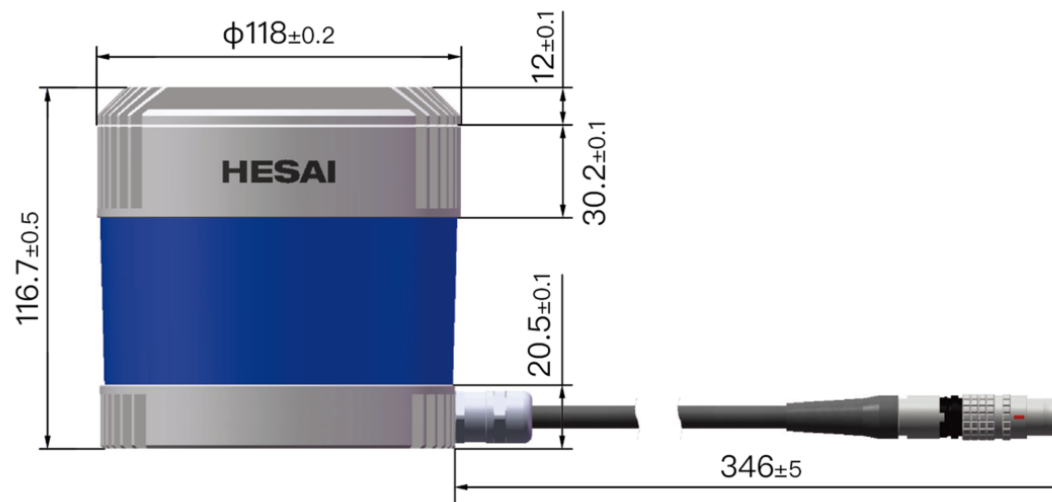

Figure 6. Front view (unit: mm)

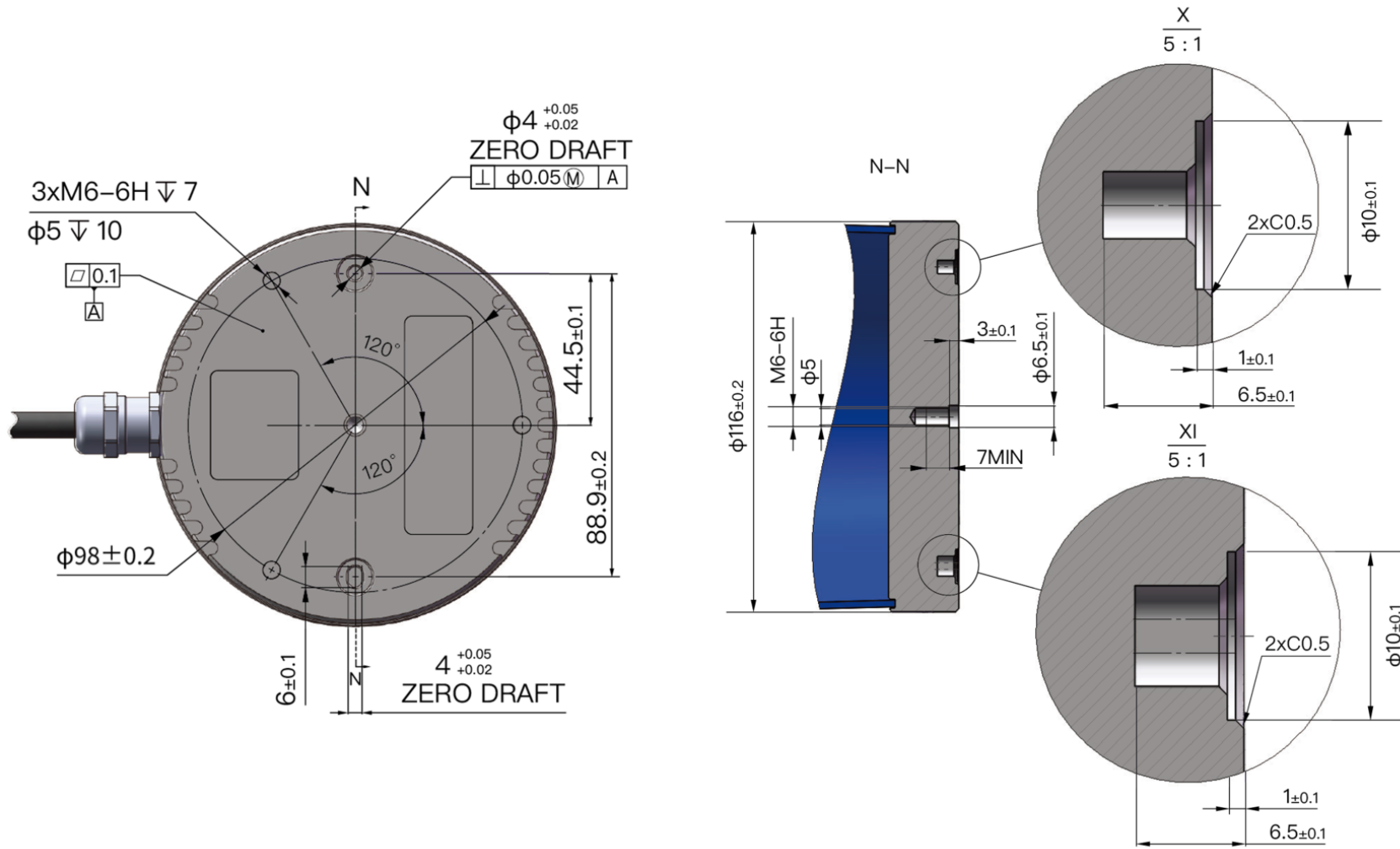

Figure 7. Bottom view (unit: mm)

### 2.1.2. Quick installation

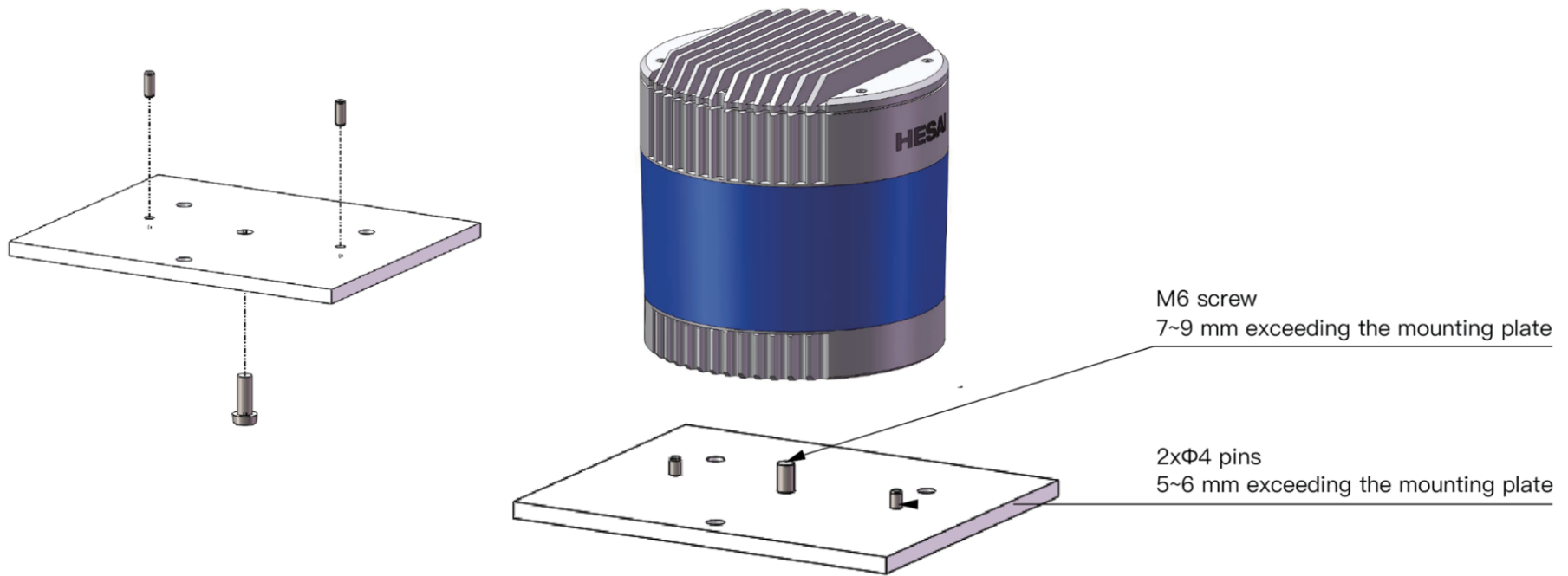

Figure 8. Quick installation

### 2.1.3. Stable installation

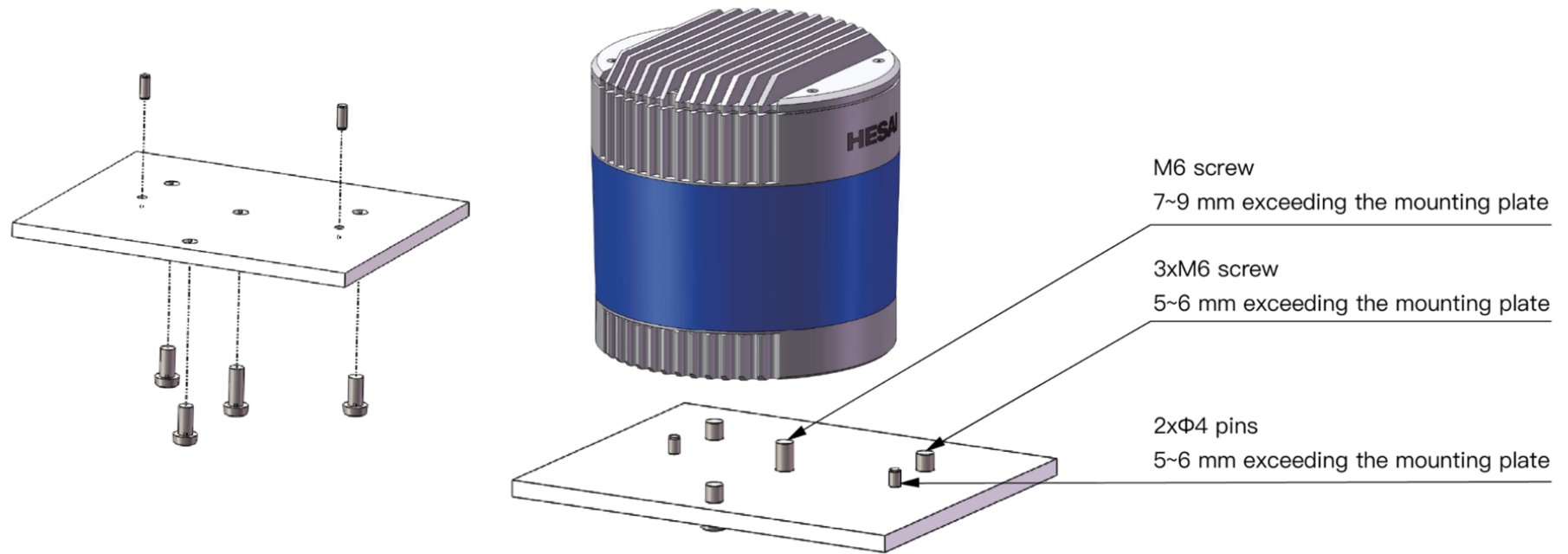

Figure 9. Stable installation

## 2.1.4. Notes on screw installation

### Screw type

SEMS screws (with pre-attached flat washers and lock washers) are recommended. Property class should be at least 4.8.

### Threadlocker

Before fastening a screw, apply 1 or 2 dots of threadlocker in the thread fit area. LOCTITE® 263 Threadlocker is recommended. To ensure curing it in place, wait for at least 12 hours before operating the lidar.

### Screw torque

The base material of the threaded holes is aluminum alloy instead of steel. Refer to the following table for the appropriate screw torque.

Thread size	Recommended screw torque
M2	0.2 to 0.3 Nm
M3	0.5 to 0.6 Nm
M4	1 to 1.5 Nm
M5	2 to 2.5 Nm
M6	3.5 to 4 Nm

### Thread service life

25 times. (Each screwing counts as one time, so as each unscrewing.)



## 2.2. Electrical interface

Lemo connector is the default communication connector. Another option is the Phoenix connector, detailed in [Appendix C Phoenix connector](#).

Lemo part number: FGG.2T.316.CLAC75Z (male plug, on the lidar)

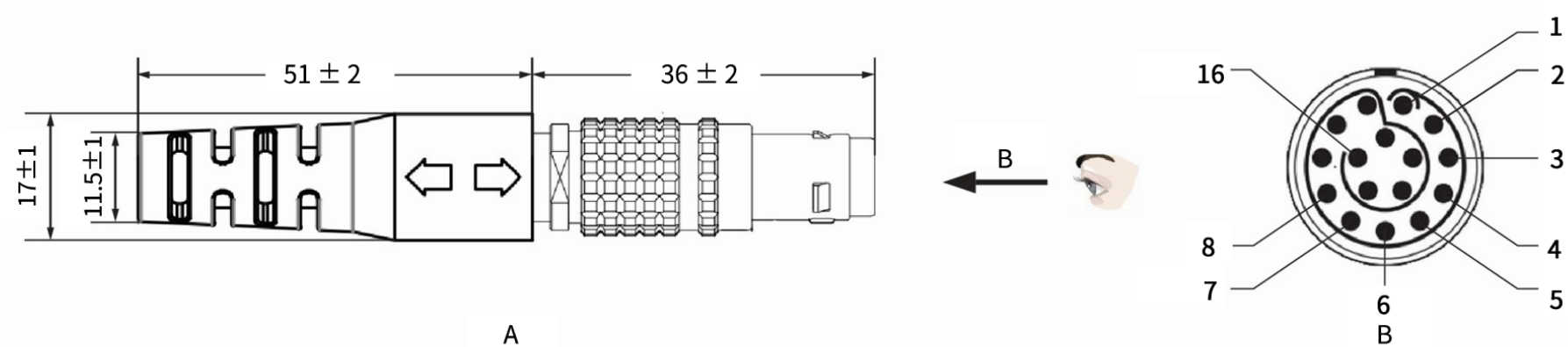

Figure 10. Lemo connector (unit: mm)

### 2.2.1. Pin description

Pin No.	Signal	Wire color	Voltage	Pin No.	Signal	Wire color	Voltage
1 to 4	-	-	-	11	Power	Red	9 to 48 V
5	Ethernet RX-	Blue	-1 to 1 V	12	Power	Gray	9 to 48 V
6	Ethernet RX+	Blue/White	-1 to 1 V	13	Ground (Return)	Black	0 V
7	Ethernet TX-	Orange	-1 to 1 V	14	Ground (Return)	Gray/White	0 V
8	Ethernet TX+	Orange/White	-1 to 1 V	15	Index	Purple	0 to 3.3 V
9	GPS NMEA	White	-13 to 13 V	16	Encoder	Purple/White	0 to 3.3 V
10	GPS PPS	Yellow	TTL 3.3/5 V	-	-	-	-

- i** For the GPS PPS signal, the pulse width is recommended to be over 1 ms, and the cycle is 1 s (rising edge to rising edge).
- !**
- Before connecting or disconnecting an external GPS signal (either using the cable's GPS wire or via the connection box's GPS port), make sure the lidar is powered off.
  - If the lidar has to stay powered on, make sure to ground yourself in advance. Do NOT touch the GPS wire or GPS port with bare hands.

Timing requirements of GPS PPS and NMEA

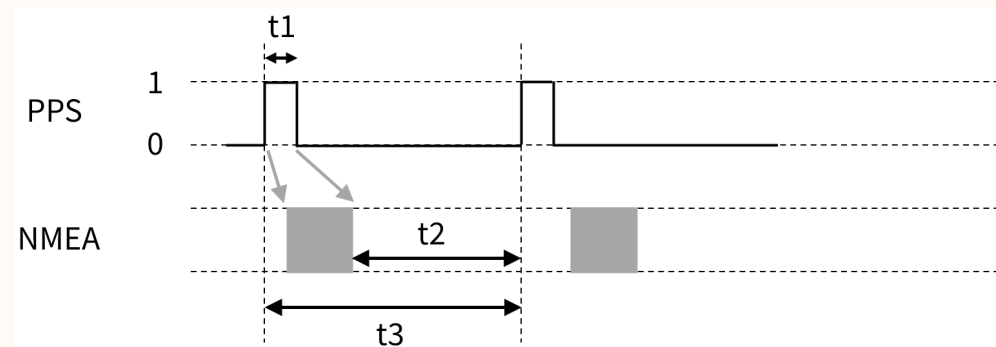

GPS PPS: signal cycle	$t_3 = 1 \text{ s} \pm 50 \mu\text{s}$ (rising edge to rising edge)
GPS PPS: pulse width	$t_1 \geq 1 \text{ ms}$ (10 to 100 ms recommended)
Timing relationship	NMEA signal starts after the PPS rising edge of the current second, and ends after the PPS falling edge of the current second, as shown by the gray arrows in the figure above.  NMEA signal ends before the PPS rising edge of the next second; $t_2 \geq 100 \text{ ms}$ .

## 2.2.2. Connector use

Connection	<ol style="list-style-type: none"> <li>1. Turn off the power source.</li> <li>2. Align the red dots on the connector shells.</li> <li>3. Push the plug straight into the socket.</li> </ol>
Disconnection	<ol style="list-style-type: none"> <li>1. Turn off the power source.</li> <li>2. Pull the release sleeve on the male connector to its outermost position and hold it.</li> <li>3. Pull the plug from the socket.</li> </ol>

Before connection: Align the red dots

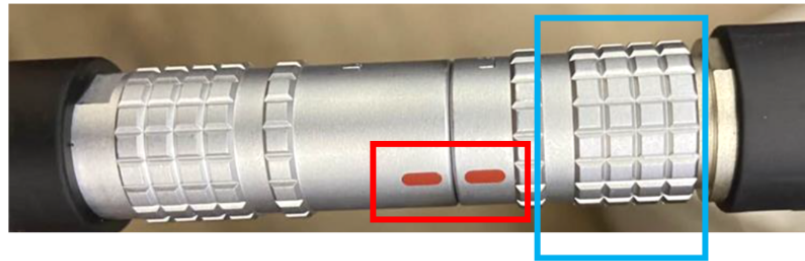

Before disconnection: Pull the release sleeve to its outermost position and hold it there

Figure 11. Lemo connection/disconnection



- Before connection, check the pins on the socket and the holes on the plug. In case of bent pins or damaged holes, stop using the connector and contact technical support.
- To prevent breakdowns, turn off the power source before connection and disconnection.
- Do NOT attempt to force open a connection by pulling on the cables or by twisting the connectors in any way. Doing so can loosen the connectors' shells, or even damage the contacts.
- If the connector's shell is accidentally pulled off, stop using the connector and contact Hesai technical support.
- Do NOT attempt to assemble the connector's shell and cable collet; do NOT connect a connector without its shell. Doing so may damage the lidar's circuits.

- For further troubleshooting, please contact Hesai's technical support or obtain work instructions from the connector manufacturer.
- The connector is designed to withstand at least 1000 mating cycles; exceeding this number may increase the risk of connector damage.

### 2.2.3. Cables (Ethernet)

Outer diameter (OD) =  $7.50 \pm 0.30$  mm

Minimum bend radius:  $7.5 \times OD$



To avoid damaging the cable, do not bend the cable at the cable gland.

## 2.3. Connection box (optional)

Users may connect the lidar with or without a connection box.

Lemo part number: PHG.2T.316.CLCC75Z (female socket, on the connection box)

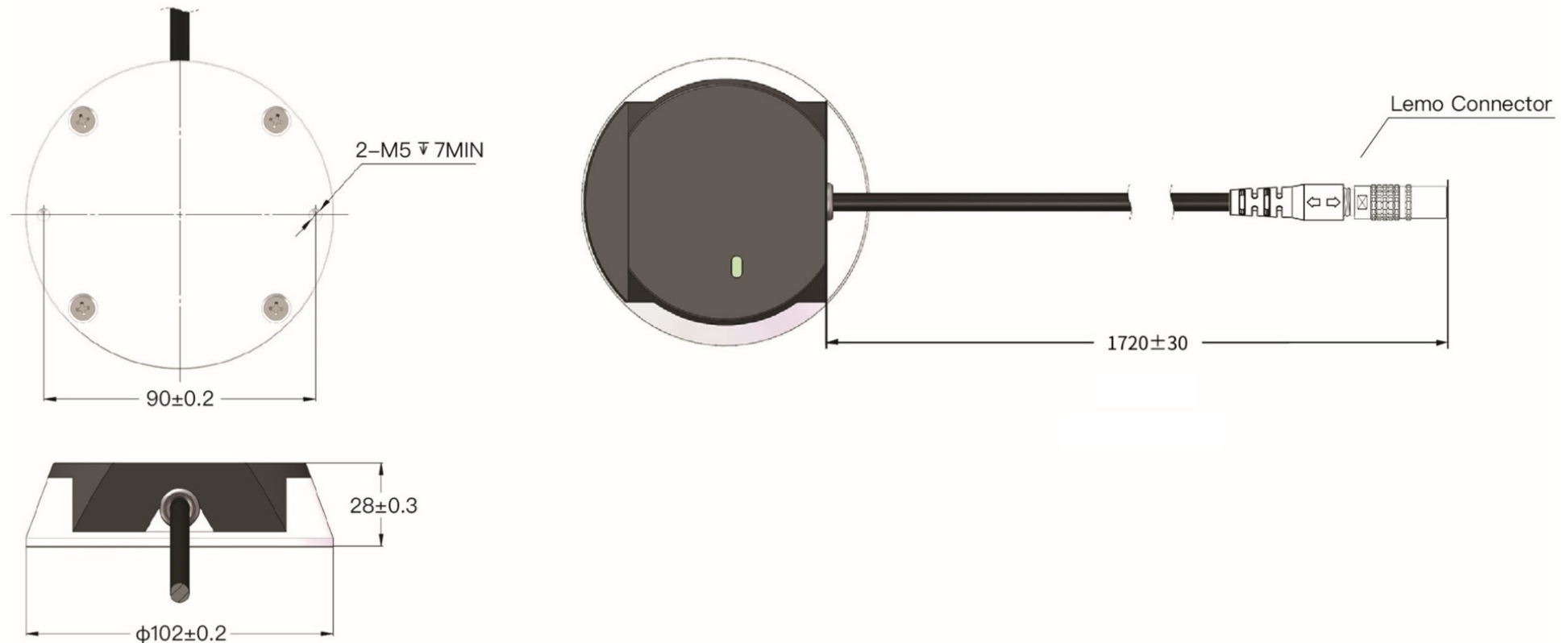

Figure 12. Connection box (unit: mm)

### 2.3.1. Ports

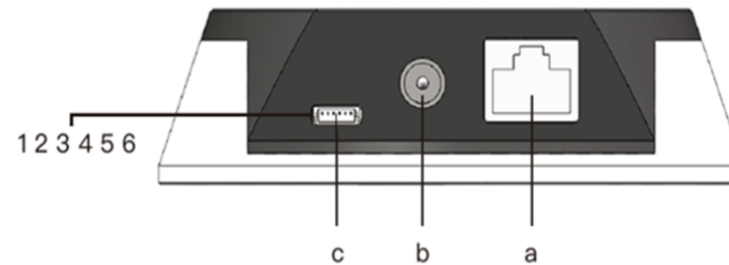

Figure 13. Connection box (front)

Port number	Port name	Description
a	Standard Ethernet port	RJ45, 100 Mbps Ethernet
b	Power port	Connects to a DC-005 DC power adapter.
c	GPS port	Connector type: JST, SM06B-SRSS-TB Recommended connector for the external GPS module: JST, SHR-06V-S-B Voltage standard: RS232 Baud rate: 9600 bps

GPS port pins (left to right):

Pin No.	Direction	Description	Requirements
1	Input	PPS signal for synchronization	TTL level 3.3/5 V  Recommended pulse width: $\geq 1$ ms Signal cycle: 1 s (rising edge to rising edge)
2	Output	Power for the external GPS module	5 V
3	Output	Ground for the external GPS module	-

### 2.3. Connection box (optional)

Pin No.	Direction	Description	Requirements
4	Input	Receiving serial data from the external GPS module	RS232 level
5	Output	Ground for the external GPS module	-
6	-	Reserved	-

For Pandar64 lidars with Lemo connectors, a trigger port is added to output external trigger signals.

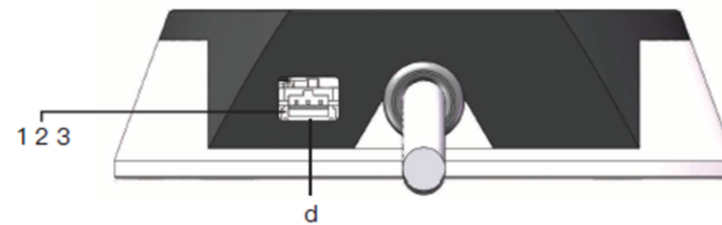

Figure 14. Connection box (back)

Port No.	Port name	Description
d	Trigger port	<p>Outputs external trigger signals for multi-sensor synchronization.</p> <p>Connector (male socket): Molex, LLC 5023520300            Recommended wire connector (female plug): Molex, LLC 5023510300            Voltage: 0 to 3.3 V            Signal type: Pulse            Max. current output level: 3 mA</p>

Pin description for the Trigger port:

Pin No.	Direction	Pin Description
1	Input	GND, to ground the external trigger signal.
2	Output	<p>Trigger signal (Encoder): outputs one pulse when the lidar rotates 0.05°.</p> <p>Pulse width: 7 <math>\mu</math>s @ 600 RPM, 3.5 <math>\mu</math>s @ 1200 RPM</p>
3	Output	<p>Trigger signal (Index): outputs one pulse when <b>Channel 18</b> passes the lidar's 180° position (see <a href="#">Figure 3. Rotation direction (top view)</a>).</p> <p>Pulse width: 4 <math>\mu</math>s @ 600 RPM, 2 <math>\mu</math>s @ 1200 RPM</p>



### 2.3.2. Connection

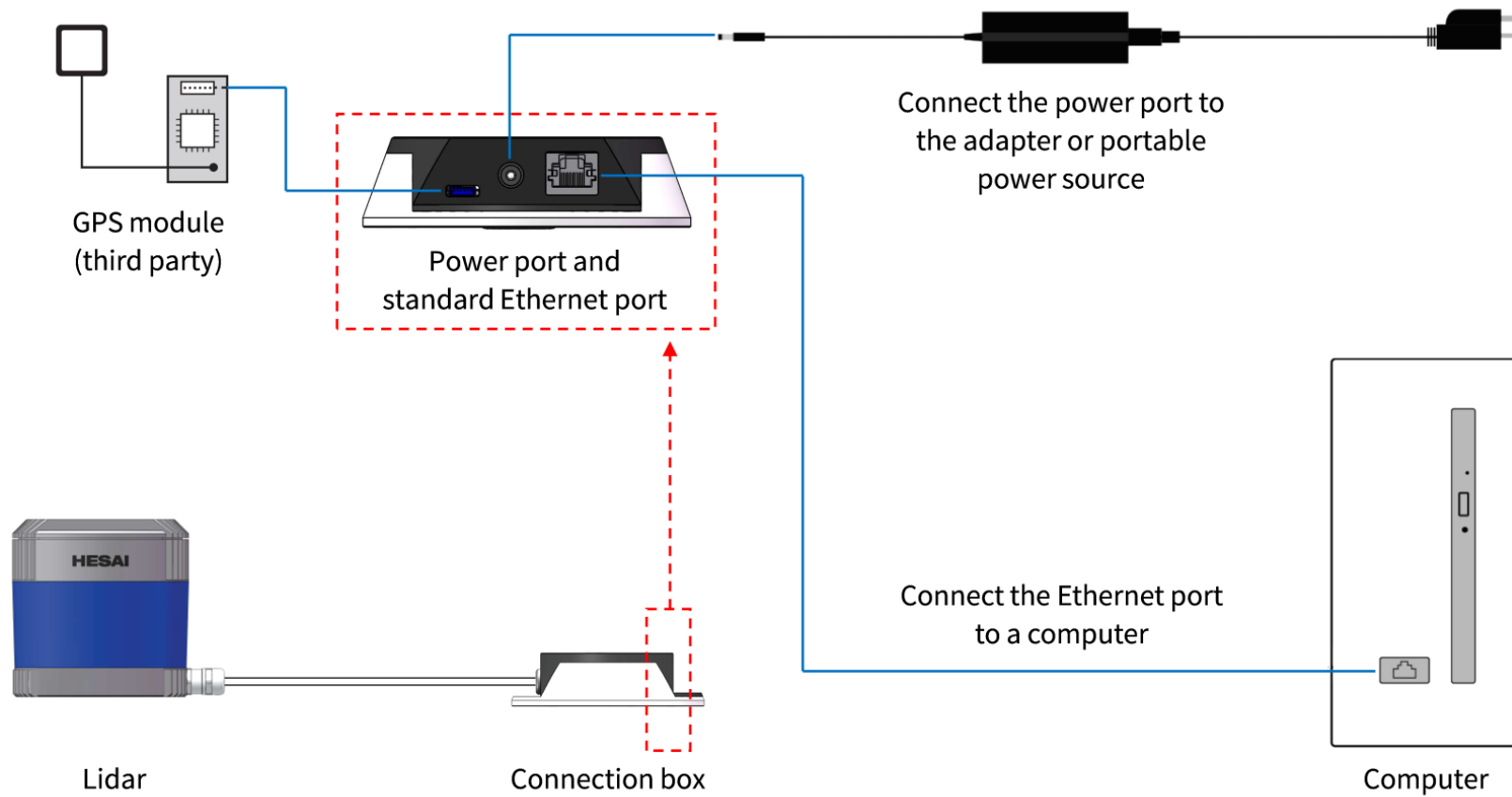

Figure 15. Connection box (connection with GPS)

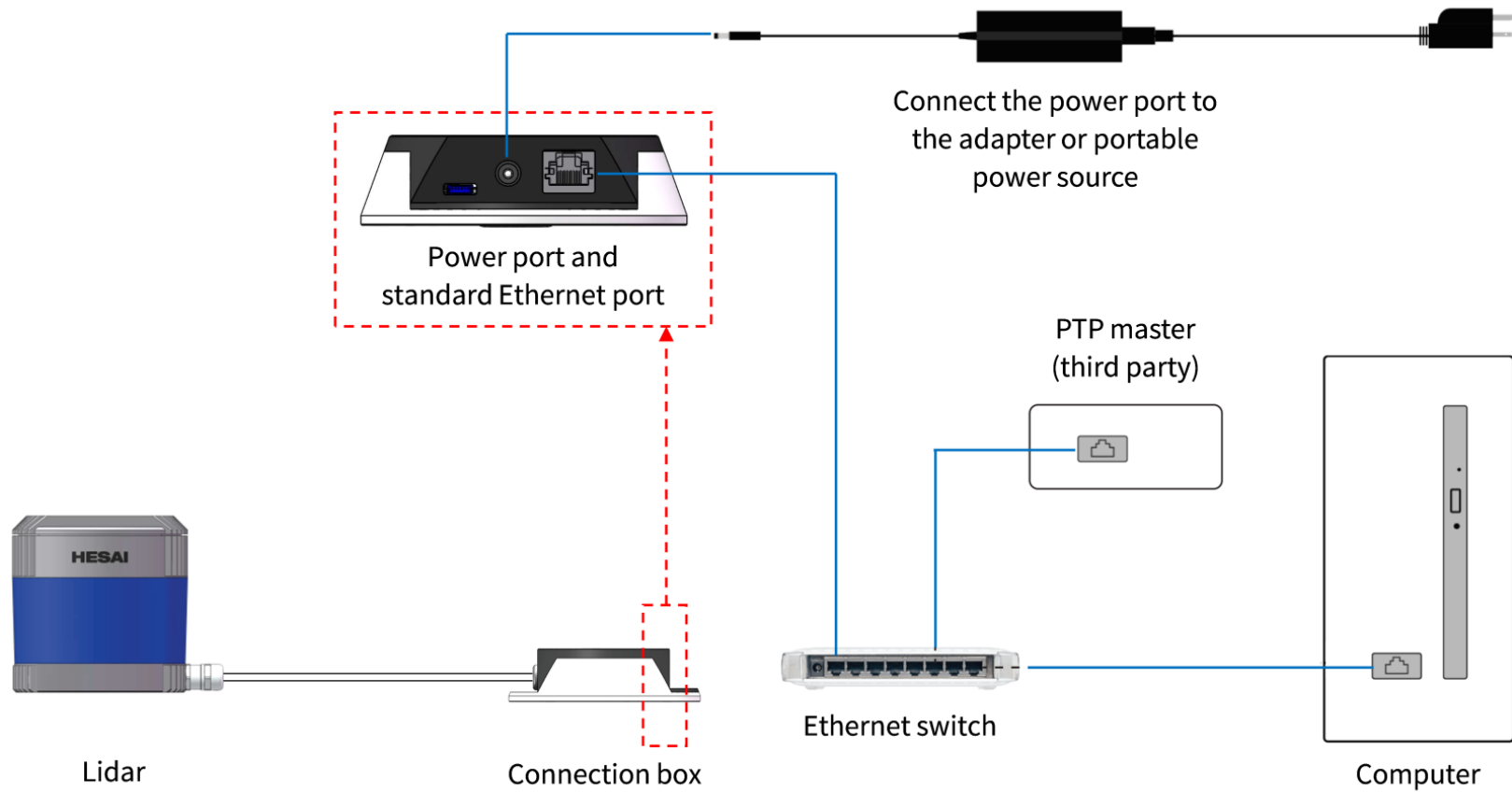

Figure 16. Connection box (connection with PTP)

## 2.4. Network settings on the receiving host

The lidar does not have a power switch. It starts transmitting data when both of these conditions are met:

- The lidar is connected to power.
- The lidar is connected to a host computer via Ethernet.

To analyze point cloud data, configure the network parameters of the host computer:

Network parameters	Value	Description
IP address	192.168.1.X	Given the lidar's IP address (192.168.1.201) and subnet mask (255.255.255.0), the following can be determined: <ul style="list-style-type: none"><li>• Network address: 192.168.1.0</li><li>• Gateway address: 192.168.1.1</li><li>• Broadcast address: 192.168.1.255</li></ul> Therefore, X can be selected from 2 to 200 and from 202 to 254.
Subnet mask	255.255.255.0	-
VLAN ID	Range: 1 to 4094	Required only when VLAN tagging is used. Make sure the host computer and the lidar use the same VLAN ID.

### 2.4.1. In Windows

1. [ **Control Panel** ] > [ **Network and Internet** ] > [ **Network and Sharing Center** ] > [ **Change adapter settings** ].
2. Right-click [ **Ethernet** ] or [ **Ethernet X** ] which shows Ethernet connection (with no red cross at the bottom left of the icon) > Select [ **Properties** ].

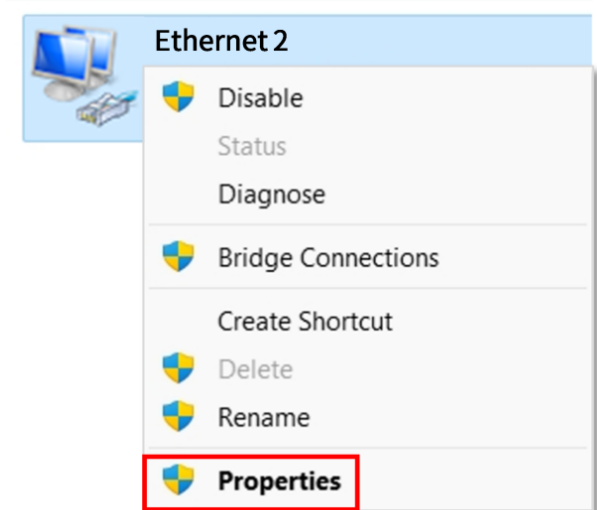
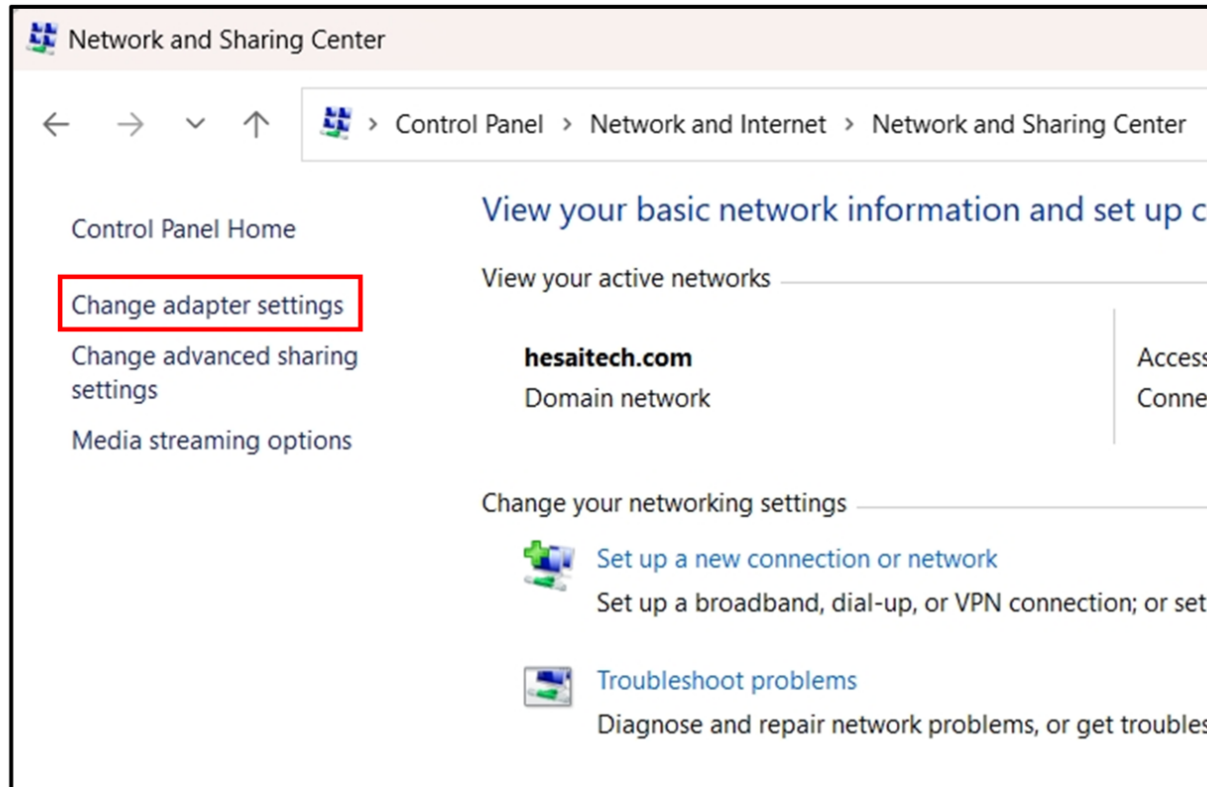

3. Double-click [ **Internet Protocol Version 4 (TCP/IPv4)** ].
4. Select [ **Use the following IP addresses** ] > Input the host computers's IP address and subnet mask.

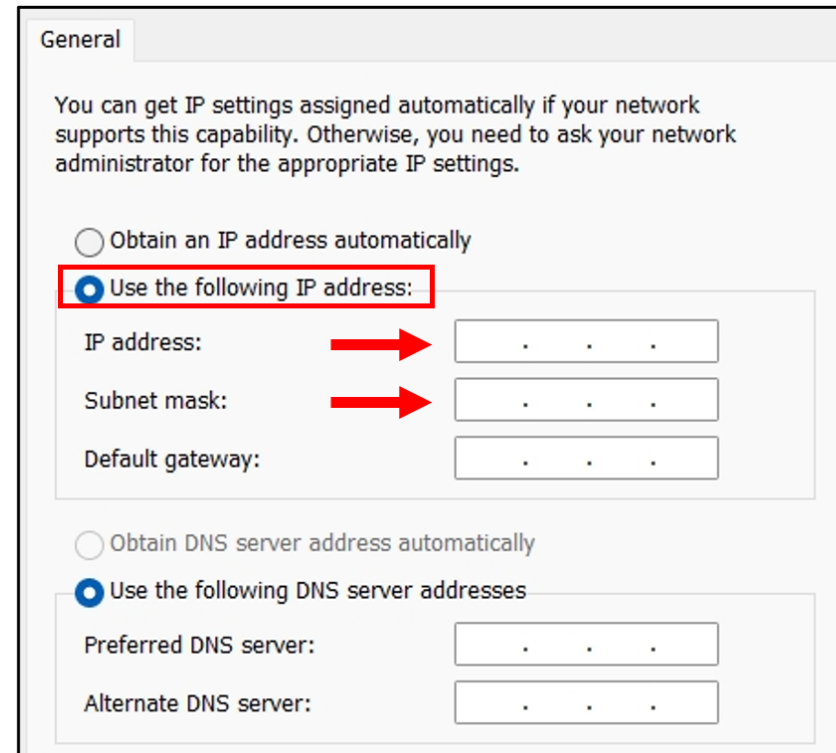
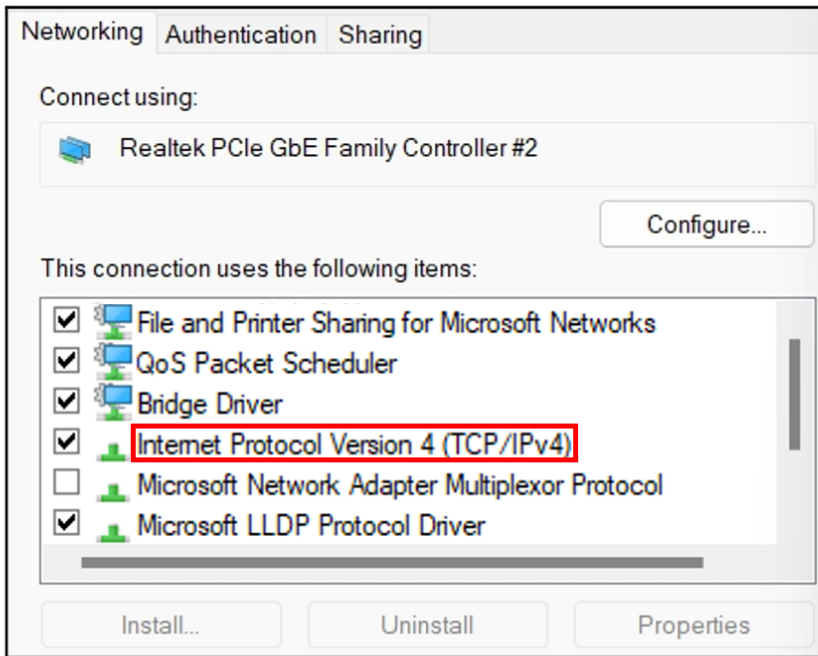

Ping command can be used to check the connection:

1. Press Win + R to open the Run dialog box.
2. Enter "cmd" and click [ **OK** ] to open the Command Prompt.
3. Enter "ping 192.168.1.201" and check the output.

5. To enable VLAN tagging:

Click [ **Configure** ] > Under the [ **Advanced** ] tag, select [ **VLAN ID** ] from the [ **Property** ] list > Input a VLAN ID in the [ **Value** ] box > Click [ **OK** ].

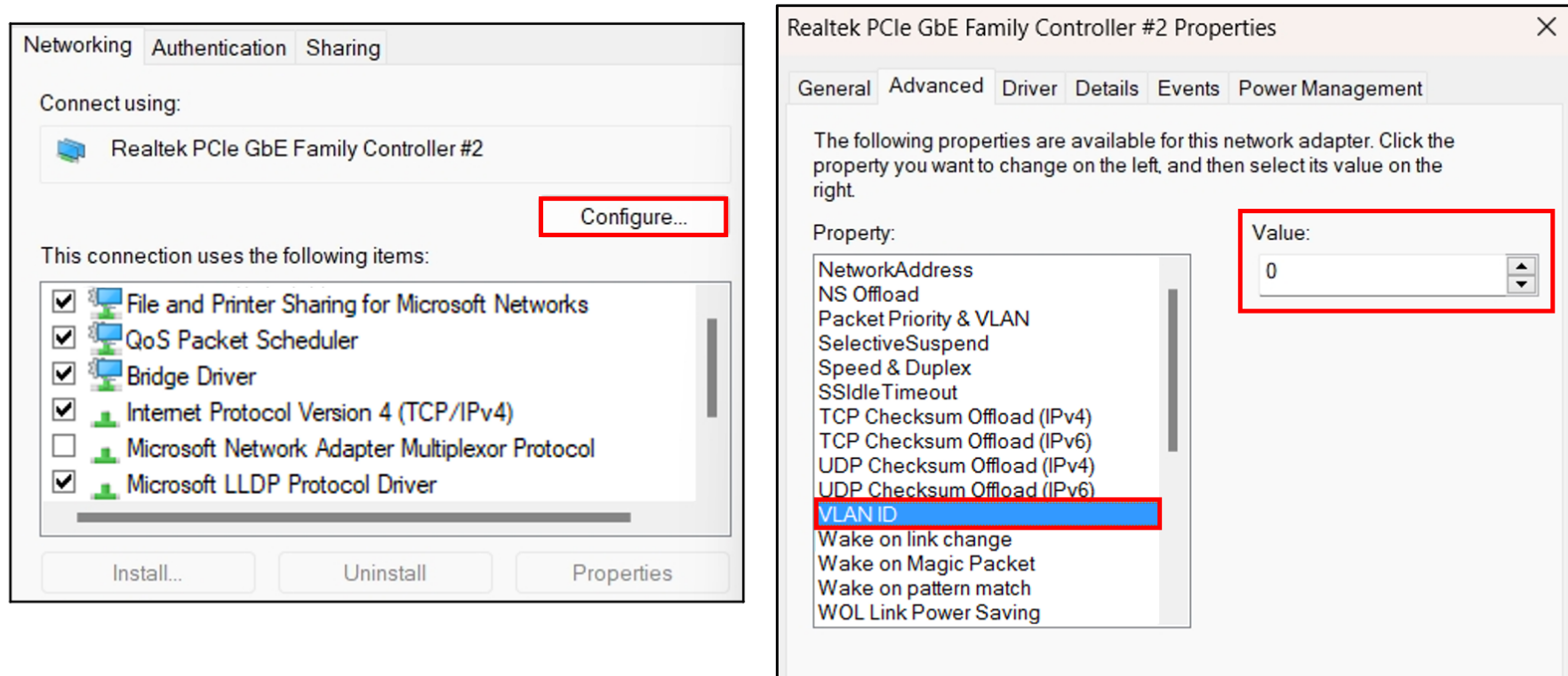

**i** If the [ **Property** ] list has no [ **VLAN ID** ], it is recommended to update the network adapter driver.

## 2.4.2. In Ubuntu

### 2.4.2.1. When not using VLAN

Run this command in the terminal:

```
sudo ifconfig ${interface_name} ${ip_addr}
```

- Replace `${interface_name}` with the host computer's network interface name.
- Replace `${ip_addr}` with the host computer's IP address.

### 2.4.2.2. When using a VLAN

Run this command in the terminal:

```
sudo ip link add link ${interface_name} name ${interface_name}.${vlan_id} type vlan id ${vlan_id}
sudo ip link set up ${interface_name}.${vlan_id}
sudo ip addr add ${ip_addr}/24 dev ${interface_name}.${vlan_id}
ip addr show ${interface_name}.${vlan_id}
```

- Replace `${interface_name}` with the host computer's network interface name.
- Replace `${vlan_id}` with the host computer's VLAN ID.
- Replace `${ip_addr}` with the host computer's IP address.

To find the host computer's network interface name:

### Method 1

In the Settings — Network page, the content in brackets after [ **Ethernet** ] is the network interface name.





**Method 2**

Enter "ifconfig" in the terminal.

```
> ifconfig
docker0: flags=4099<UP,BROADCAST,MULTICAST> mtu 1500
    inet [REDACTED] netmask [REDACTED] broadcast [REDACTED]
    ether [REDACTED] txqueuelen 0 (Ethernet)
    RX packets 0 bytes 0 (0.0 B)
    RX errors 0 dropped 0 overruns 0 frame 0
    TX packets 0 bytes 0 (0.0 B)
    TX errors 0 dropped 0 overruns 0 carrier 0 collisions 0

enp2s0f0: flags=4099<UP,BROADCAST,MULTICAST> mtu 1500
    ether [REDACTED] txqueuelen 1000 (Ethernet)
    RX packets 0 bytes 0 (0.0 B)
    RX errors 0 dropped 0 overruns 0 frame 0
    TX packets 0 bytes 0 (0.0 B)
    TX errors 0 dropped 0 overruns 0 carrier 0 collisions 0

enp5s0: flags=4099<UP,BROADCAST,MULTICAST> mtu 1500
    ether [REDACTED] txqueuelen 1000 (Ethernet)
    RX packets 267706980 bytes 300970909734 (300.9 GB)
    RX errors 0 dropped 0 overruns 0 frame 0
    TX packets 3184 bytes 590575 (590.5 KB)
    TX errors 0 dropped 0 overruns 0 carrier 0 collisions 0
```

## 2.5. Tools

Tool	Purpose	Where to find it
PandarView 2	Point cloud visualization software: To record and display point cloud data.	Visit the <a href="#">Download page of Hesai's official website</a> .
Web Control	To set parameters, check device info, or upgrade firmware and software.	See <a href="#">Section 4 Web Control</a> .
HTTP API	To set parameters, check device info, or upgrade firmware and software.	Please contact Hesai technical support.
Pandar TCP Commands (PTC) API	To set parameters, check device info, or upgrade firmware and software.   Network parameters: <ul style="list-style-type: none"> <li>• Default Source IPv4 address: 192.168.1.201</li> <li>• Default PTC port: 9347</li> </ul>	Please contact Hesai technical support.
Software development kits (SDKs) and ROS drivers	To assist development.	Visit Hesai's official GitHub page: <a href="https://github.com/HesaiTechnology">https://github.com/HesaiTechnology</a>

## 3. Data structure

Unless otherwise specified, all the multi-byte fields are unsigned values in little-endian format.

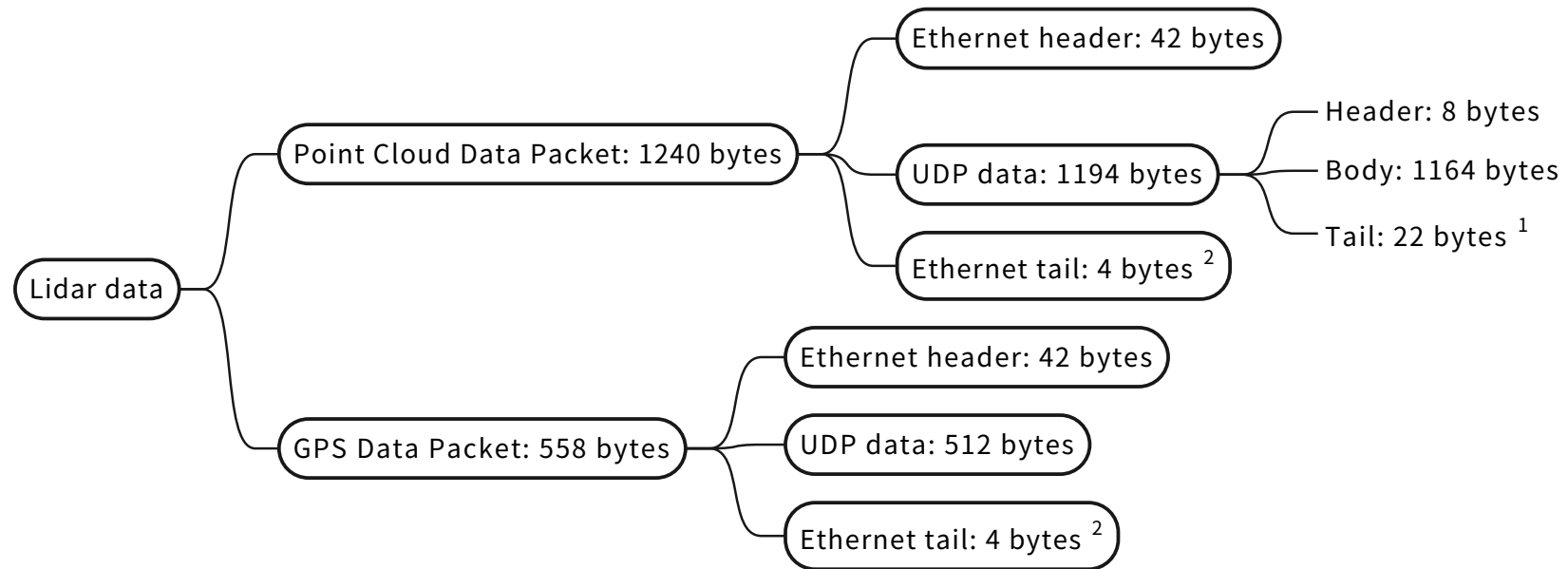

1. UDP sequence is OFF by default. When UDP sequence is ON, the **Tail** part will be 26 bytes instead.
2. Network monitoring software (such as WireShark) usually does not display the **Ethernet tail** (4 bytes).

Figure 17. Data structure

## 3.1. Point Cloud Data Packet

Before receiving Point Cloud Data Packets, please perform [Section 2.4 Network settings on the receiving host](#).

### 3.1.1. Ethernet header

#### Point Cloud Data Packet: Ethernet header

Field	Byte(s)	Description
Ethernet II MAC	12	Destination MAC: xx:xx:xx:xx:xx:xx (FF:FF:FF:FF:FF:FF for broadcast) Source MAC: xx:xx:xx:xx:xx:xx
Ethernet Data Packet Type	2	0x08, 0x00
Internet Protocol	20	Protocol parameters
UDP Port Number	4	Source port (default: 10000) Destination port (default: 2368)
UDP Length	2	Eight bytes more than point cloud UDP data (see <a href="#">Figure 17. Data structure</a> ).
UDP Checksum	2	Checksum of the Ethernet header

## 3.1.2. Point cloud UDP data

### 3.1.2.1. Header

Field	Byte(s)	Description
Start of Packet	1	0xEE
Start of Packet	1	0xFF
Laser N	1	0x40 (64 channels)
Block N	1	0x06 (6 blocks per packet)
Reserved	1	-
Dis Unit	1	Fixed: 0x04 (4 mm)
Reserved	1	-
Reserved	1	-

### 3.1.2.2. Body

#### Return mode

See **Return Mode** field in [Section 3.1.2.3 Tail](#).

In Single Return mode, the measurements of each round of firing are stored in one block.







In Dual Return mode, the measurements of each round of firing are stored in two adjacent blocks, and the **Azimuth** fields of these two blocks are the same.

Return mode	Odd-numbered block	Even-numbered block	Note
Last and Strongest	Last return	Strongest return	If the last return is also the strongest, then the even-numbered block stores the second strongest return.

Block 1	Block 2	Block 3	...	Block 6
Azimuth 1	Azimuth 2	Azimuth 3	...	Azimuth 6
Channel 1	Channel 1	Channel 1	...	Channel 1
Channel 2	Channel 2	Channel 2	...	Channel 2
...	...	...	...	...
Channel 64	Channel 64	Channel 64	...	Channel 64



#### Each block in the body

Field	Byte(s)	Description
Azimuth	2	Current reference angle of the azimuth Unit: 0.01°

Field	Byte(s)	Description									
Channel 1	3	Measurements of Channel 1									
		<table border="1"> <thead> <tr> <th>Field</th> <th>Bytes</th> <th>Description</th> </tr> </thead> <tbody> <tr> <td>Distance</td> <td>2</td> <td>Object distance = <b>Distance</b> × <b>Dis Unit</b>    <b>Dis Unit</b> is specified in <a href="#">Section 3.1.2.1 Header</a>.</td> </tr> <tr> <td>Reflectivity</td> <td>1</td> <td>Range: 0 to 255             Default: linear mapping (Reflectivity = <b>Reflectivity</b> × 1%)            Also refer to <a href="#">Appendix D Nonlinear reflectivity mapping</a>.    The mapping between this field and target reflectivity can be selected using Web Control or PTC commands.</td> </tr> </tbody> </table>	Field	Bytes	Description	Distance	2	Object distance = <b>Distance</b> × <b>Dis Unit</b>   <b>Dis Unit</b> is specified in <a href="#">Section 3.1.2.1 Header</a> .	Reflectivity	1	Range: 0 to 255  Default: linear mapping (Reflectivity = <b>Reflectivity</b> × 1%) Also refer to <a href="#">Appendix D Nonlinear reflectivity mapping</a> .   The mapping between this field and target reflectivity can be selected using Web Control or PTC commands.
		Field	Bytes	Description							
Distance	2	Object distance = <b>Distance</b> × <b>Dis Unit</b>   <b>Dis Unit</b> is specified in <a href="#">Section 3.1.2.1 Header</a> .									
Reflectivity	1	Range: 0 to 255  Default: linear mapping (Reflectivity = <b>Reflectivity</b> × 1%) Also refer to <a href="#">Appendix D Nonlinear reflectivity mapping</a> .   The mapping between this field and target reflectivity can be selected using Web Control or PTC commands.									
...	...	...									
Channel 64	3	Measurements of Channel 64									

### 3.1.2.3. Tail

Field	Byte(s)	Description
Reserved	5	-

High Temperature Shutdown Flag	1	<p>0x01 — High temperature 0x00 — Normal operation</p> <ul style="list-style-type: none"> <li>• When high temperature is detected, the Shutdown Flag will be set to 0x01, and the system will shut down after 60 s. The flag remains 0x01 during the 60 s and the shutdown period.</li> <li>• When the system is no longer in high-temperature status, the Shutdown Flag will be reset to 0x00, and the system will automatically return to normal operation.</li> </ul>
Reserved	2	-
Motor Speed	2	<p>Unit: RPM</p> <p> Spin rate of the motor (RPM) = frame rate (Hz) × 60</p>
Timestamp	4	<p>The microsecond part of the Coordinated Universal Time (UTC) of this data packet. Unit: <math>\mu</math>s Range: 0 to 999 999 <math>\mu</math>s (1 s)</p> <p> The absolute time of a Point Cloud Data Packet is defined in <a href="#">Appendix B Absolute time of point cloud data</a>.</p>
Return Mode	1	<p>0x37 — Strongest 0x38 — Last 0x39 — Last and Strongest</p>
Factory Information	1	0x42 (or 0x43)



Date & Time	6	Absolute time of this data packet, accurate to the second.	
		Each byte	Range (decimal)
		Year (current year minus 2000)	Positive integers
		Month	1 to 12
		Day	1 to 31
		Hour	0 to 23
		Minute	0 to 59
		Second	0 to 59
		 The absolute time of the Point Cloud Data Packets is defined in <a href="#">Appendix B Absolute time of point cloud data</a> .	
UDP Sequence	4	Sequence number of this data packet Added only when the UDP sequence is ON. Range: 0 to 0xFF FF FF FF	

### 3.1.3. Ethernet tail

Field	Byte(s)	Description
FCS	4	Frame check sequence

### 3.1.4. Point cloud data analysis method

Take **Channel 5** in **Block 3** as an example.

#### 3.1.4.1. Analyze the vertical angle of a data point

The designed vertical angle of **Channel 5** is  $3.04^\circ$ , according to [Appendix A Channel distribution data](#).



- The accurate vertical angles are recorded in the angle correction file of this lidar (see [Section 1.4 Channel distribution](#)).
- The horizontal direction is  $0^\circ$ . The upward direction is defined as positive (see [Figure 4. Channel vertical distribution](#)).

### 3.1.4.2. Analyze the horizontal angle of a data point

 The Y-axis of the lidar coordinate system is 0°. The clockwise direction (as viewed from above) is defined as positive (see [Figure 3. Rotation direction \(top view\)](#)).

$$\text{Horizontal angle} = \textcircled{1} + \textcircled{2}$$

- ① Angular position of the current block (see [Section B.3 End time of each block](#))
- ② Firing time angular offset of the current firing channel

$$\textcircled{1} = \textcircled{3} + \textcircled{4}$$

- ③ Current reference azimuth of this block  
Can be read from the **Azimuth** field of **Block 3**. See [Section 3.1.2.2 Body](#).
- ④ Horizontal angle offset of the current firing channel  
The offset of **Channel 5** is  $-1.042^\circ$ , according to [Appendix A Channel distribution data](#).

 The accurate horizontal angle offsets are recorded in the angle correction file of this lidar (see [Section 1.4 Channel distribution](#)).

$$\textcircled{2} = \textcircled{5} \times \textcircled{6}$$

- ⑤ Firing time offset of the current firing channel  
The offset of **Channel 5** is  $-17.964 \mu\text{s}$ , according to [Section B.4 Laser firing time of each channel](#).
- ⑥ Spin rate of the motor  
See the **Motor Speed** field in [Section 3.1.2.3 Tail](#). The unit should be converted to  $^\circ/\text{s}$ .

### 3.1.4.3. Analyze the distance of a data point

See the **Distance** field of **Block 3: Channel 5** in [Each block in the body](#).

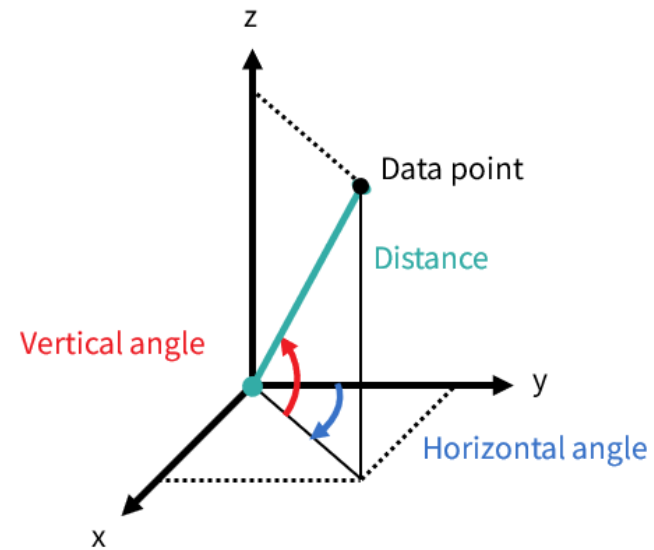
**3.1.4.4. Draw the data point in a spherical or rectangular coordinate system****3.1.4.5. Obtain the real-time point cloud data by analyzing and drawing every data point in each frame**

## 3.2. GPS Data Packet

- Please configure network parameters on the receiving host before receiving GPS Data Packet. See [Section 2.4 Network settings on the receiving host](#).
- When GPS is selected as the clock source, a GPS Data Packet is triggered every second; When PTP is selected as the clock source, the lidar does not output GPS Data Packet.

 To select the clock source, refer to [Section 4.2.3 Time sync](#).

All the multi-byte values are unsigned and in little-endian format.

### 3.2.1. Ethernet header

#### GPS Data packet: Ethernet header

Field	Byte(s)	Description
Ethernet II MAC	12	Destination MAC: xx:xx:xx:xx:xx:xx (FF:FF:FF:FF:FF:FF for broadcast) Source MAC: xx:xx:xx:xx:xx:xx
Ethernet Data Packet Type	2	0x08, 0x00
Internet Protocol	20	Protocol parameters
UDP Port Number	4	Source port (default: 10000) Destination port (default: 10110)
UDP Length	2	8 bytes more than GPS UDP data; see <a href="#">Figure 17. Data structure</a>
UDP Checksum	2	Checksum of the Ethernet header

## 3.2.2. GPS UDP data

Field	Byte(s)	Description															
GPS Time Data	18	GPS time, accurate to the second															
		<table border="1"> <thead> <tr> <th>Field</th> <th>Bytes</th> <th>Description</th> </tr> </thead> <tbody> <tr> <td>GPS Header</td> <td>2</td> <td>0xFFEE (0xFF first)</td> </tr> <tr> <td>Date</td> <td>6</td> <td>Year, month, and day in ASCII (2 bytes each, lower byte first)</td> </tr> <tr> <td>Time</td> <td>6</td> <td>Second, minute, and hour in ASCII (2 bytes each, lower byte first)</td> </tr> <tr> <td>Reserved</td> <td>4</td> <td>-</td> </tr> </tbody> </table>	Field	Bytes	Description	GPS Header	2	0xFFEE (0xFF first)	Date	6	Year, month, and day in ASCII (2 bytes each, lower byte first)	Time	6	Second, minute, and hour in ASCII (2 bytes each, lower byte first)	Reserved	4	-
		Field	Bytes	Description													
		GPS Header	2	0xFFEE (0xFF first)													
		Date	6	Year, month, and day in ASCII (2 bytes each, lower byte first)													
Time	6	Second, minute, and hour in ASCII (2 bytes each, lower byte first)															
Reserved	4	-															
NMEA Data	84	<p>NMEA sentence containing date and time ASCII code, valid till 2 bytes after the asterisk (*).</p> <p> Users can select the NMEA sentence to be received (see <b>GPS Mode</b> in <a href="#">Section 4.2.3 Time sync</a>).</p>															
Reserved	404	404 bytes of 0xDF															
GPS Positioning Status	1	ASCII code, obtained from the NMEA sentence															
PPS Lock Flag	1	1 – Locked 0 – Unlocked															
Reserved	4	-															

## 3.2.2.1. GPRMC data format

```
$GPRMC, <01>, <02>, <03>, <04>, <05>, <06>, <07>, <08>, <09>, <10>, <11>, <12>*hh
```

Field No.	Field	Description
<01>	UTC Time	Hour, minute, and second Typically in hhmmss (hour, minute, second) format
<02>	Location Status	A (hex = 41) — Active (valid position) V (hex = 56) — Void (invalid position) NUL (hex = 0) — GPS unlocked
...	...	...
<09>	UTC Date	Date information Typically in ddmmyy (day, month, year) format
...	...	...

The lidar's GPS data interface accepts a variety of GPRMC formats, as long as:

Field <01> (after the first comma separator) is the hour, minute, and second information.  
Field <09> (after the ninth comma separator) is the date information.

For example, the following formats are both acceptable:

```
$GPRMC,072242,A,3027.3680,N,11423.6975,E,000.0,316.7,160617,004.1,W*67
$GPRMC,065829.00,A,3121.86377,N,12114.68322,E,0.027,,#160617#,,,A*74
```

## 3.2.2.2. GPGGA data format

```
$GPGGA, <01>, <02>, <03>, <04>, <05>, <06>, <07>, <08>, <09>, <10>, <11>, <12>*hh
```

Field No.	Field	Description																
<01>	UTC Time	Hour, minute, and second Typically in hhmmss (hour, minute, second) format																
...	...	...																
<06>	GPS Fix Quality	Range: 0 to 9 Refer to the description given by the GPS device provider.  Common definitions: <table border="1" data-bbox="757 730 2069 967"> <tbody> <tr> <td>0</td> <td>Invalid</td> <td>4</td> <td>RTK fix</td> </tr> <tr> <td>1</td> <td>GPS fix (SPS)</td> <td>5</td> <td>RTK float</td> </tr> <tr> <td>2</td> <td>DGPS fix</td> <td>6</td> <td>Estimated (dead reckoning)</td> </tr> <tr> <td>3</td> <td>PPS fix</td> <td>-</td> <td>-</td> </tr> </tbody> </table>	0	Invalid	4	RTK fix	1	GPS fix (SPS)	5	RTK float	2	DGPS fix	6	Estimated (dead reckoning)	3	PPS fix	-	-
0	Invalid	4	RTK fix															
1	GPS fix (SPS)	5	RTK float															
2	DGPS fix	6	Estimated (dead reckoning)															
3	PPS fix	-	-															
...	...	...																

The lidar's GPS data interface accepts a variety of GPGGA formats, as long as:

Field <01> (after the first comma separator) is the hour, minute, and second information.

For example, the following formats are both acceptable:

```
$GPGGA, 123519, 4807.038, N, 01131.000, E, 1, 08, 0.9, 545.4, M, 46.9, M, , *47
$GPGGA, 134658.00, 5106.9792, N, 11402.3003, W, 2, 09, 1.0, 1048.47, M, -6.27, M, 08, AAAA*60
```



### 3.2.3. Ethernet tail

Field	Byte(s)	Description
FCS	4	Frame check sequence

### 3.2.4. GPS time data analysis method

> Data (512 bytes)			
0000	04 d4 c4 eb 9b 37 ec 9f 0d 00 48 cb 08 00 45 00	.....7.. ..H...E.	
0010	02 1c c4 23 40 00 80 11 b0 66 c0 a8 01 c9 c0 a8	...#@... .f.....	
0020	01 2d 27 10 27 7e 02 08 00 00 ff ee 30 32 34 30	..'.~... ....0240	
0030	<u>37 30 38 35 37 30 34 30</u> 00 00 00 00 24 47 50 52	70857040 ...\$GPR	
0040	4d 43 00 2c 30 34 30 37 35 37 2e 37 36 2c 56 2c	MC.,0407 57.76,V,	
0050	2c 2c 2c 2c 2c 2c 30 37 30 34 32 30 2c 2c 2c 4e	,,,,,,07 0420,,,N	
0060	2c 56 2a 30 36 36 36 36 36 36 36 36 36 36 36	,V*06666 66666666	

Figure 18. GPS Data packet: GPS time data (example)

#### Date

Field	Data (in ASCII)	Characters	Meaning
Year	0x30 0x32	'0', '2'	20
Month	0x34 0x30	'4', '0'	04
Day	0x37 0x30	'7', '0'	07

#### Time

Field	Data (in ASCII)	Characters	Meaning
Second	0x38 0x35	'8', '5'	58
Minute	0x37 0x30	'7', '0'	07
Hour	0x34 0x30	'4', '0'	04

## 4. Web Control

Web Control is used for setting parameters, viewing device info, and upgrading software/firmware.

To access Web Control, follow the steps below:

1. Connect the lidar to your PC using an Ethernet cable.
2. Complete [Section 2.4 Network settings on the receiving host](#).
3. Enter 192.168.1.201 in your web browser.



- Google Chrome and Mozilla Firefox are recommended.
- Firewall port exceptions: Port 9347 (PTC/PTCS), Port 80 (HTTP), Port 443 (HTTPS), and Ports 319 and 320 (PTP 1588v2).

## 4.1. Home

Status	
Spin Rate	600 RPM
GPS	Unlock
NMEA (GPRMC/GPGGA)	Unlock
PTP	Free Run
Device Info	<a href="#">Device Log</a>
Model	Pandar64
S/N	PA64XXXXXXXXXXXXXXXXXX
MAC Address	XX:XX:XX:XX:XX:XX
Software Version	2.10.8
Sensor Firmware Version	4.3.44b
Controller Firmware Version	5.32

### Button description

**Device Log** Click to download a .JSON file that contains the lidar status, device info, all configurable parameters, and the upgrade log.

### Parameter description

**Spin Rate** Spin Rate of the motor (RPM) = frame rate (Hz) × 60

**GPS** GPS pulse-per-second (PPS) status

- Lock: Lidar's internal clock is in sync with GPS PPS.
- Unlock: Not in sync.

**NMEA (GPRMC/GPGGA)**

## NMEA status

- Lock: After receiving a valid NMEA message.
- Unlock: Not receiving a valid NMEA message for over 2 seconds.

**PTP**

## PTP status

- Free Run: No PTP master is selected.
- Tracking: Attempting to sync with the selected PTP Master, but the absolute offset exceeds the user-specified limit in [Section 4.2.3 Time sync](#).
- Locked: The absolute offset is within the user-specified limit.
- Frozen: The lidar has lost connection to the PTP master and is attempting to recover it. Meanwhile, lidar time will drift from the last synchronized time. When the time drift exceeds the specification, PTP status will change to Free Run.

## 4.2. Settings



		<a href="#">Reset All Settings</a>
Control IP		
IPv4 Address		192.168.1.201
IPv4 Mask		255.255.255.0
IPv4 Gateway		192.168.1.1
VLAN	<input type="checkbox"/>	0
Settings		
Destination IP		255.255.255.255
Lidar Destination Port		2368
Spin Rate		600 RPM
Return Mode		Dual Return
Sync Angle	<input type="checkbox"/>	0
Trigger Method		Time Based
Clock Source		GPS
GPS Mode		GPRMC
GPS Destination Port		10110
Noise Filtering		OFF
Interstitial Points Filtering		OFF
Retro Multi-Reflection Filtering		OFF
Up-Close Blockage Detection		OFF

Reflectivity Mapping	Linear Mapping
Standby Mode	In Operation/Standby
<a href="#">Save</a>	

### Button description

- Reset All Settings** Reset all the configurable parameters to factory defaults, including:
- [Settings](#)
  - [Azimuth FOV](#)
- Save** Save and execute all the settings on this page.  
Exception: Standby Mode takes effect immediately without having to click this button.



### 4.2.1. Network

Parameter	Options	Description								
Control IP: VLAN	Default: OFF VLAN ID: 1 to 4094	<p>To enable VLAN tagging:</p> <ul style="list-style-type: none"> <li>• Make sure the receiving host also supports VLAN;</li> <li>• Check the checkbox and input the lidar's VLAN ID (same as the receiving host's VLAN ID).</li> </ul> <p>If the lidar's VLAN ID differs from the receiving host's, users will lose access to Web Control. To minimize such risks, the VLAN ID is zero (an invalid value) by default.</p>  <ul style="list-style-type: none"> <li>• When checking the checkbox, users will be alerted to input a valid VLAN ID.</li> <li>• When unchecking the checkbox, the VLAN ID will default to zero.</li> </ul> <p> Once configured, the VLAN ID will not change during firmware upgrades. When VLAN is enabled, PTP connection will be lost; when VLAN is disabled, PTP connection will automatically recover.</p>								
Destination IP	Any except 0.0.0.0, 127.0.0.1, and the lidar's IPv4 address Default: 255.255.255.255	<p>Destination IP</p> <table border="1"> <thead> <tr> <th>Mode</th> <th>Destination IP</th> </tr> </thead> <tbody> <tr> <td>Broadcast (default)</td> <td>255.255.255.255</td> </tr> <tr> <td>Multicast</td> <td>User-defined</td> </tr> <tr> <td>Unicast</td> <td>Same as the PC's IPv4 address.</td> </tr> </tbody> </table>	Mode	Destination IP	Broadcast (default)	255.255.255.255	Multicast	User-defined	Unicast	Same as the PC's IPv4 address.
Mode	Destination IP									
Broadcast (default)	255.255.255.255									
Multicast	User-defined									
Unicast	Same as the PC's IPv4 address.									
Lidar Destination Port	Default: 2368	Destination port of point cloud data and Web Control (HTTP API)								



## 4.2.2. Function

Parameter	Options	Description
Spin Rate	600 RPM (default) 1200 RPM	The accurate spin rate is shown in Point Cloud Data Packets (see the <b>Motor Speed</b> field in <a href="#">Section 3.1.2.3 Tail</a> ). The set spin rate is also shown on the Home page (see <a href="#">Section 4.1 Home</a> ).
Return Mode	Single Return <ul style="list-style-type: none"> <li>• Last</li> <li>• Strongest</li> </ul> Dual Return  Last and Strongest	Also shown in Point Cloud Data Packets (see the <b>Return Mode</b> field in <a href="#">Section 3.1.2 Point cloud UDP data</a> ).
UDP Sequence	OFF <b>ON #1</b> <b>ON #2</b>	Point Cloud UDP Packets can be labeled with sequence numbers (see <a href="#">Section 3.1 Point Cloud Data Packet</a> ). ON #1: UDP sequence only increments within the user-specified azimuth FOV in <a href="#">Section 4.3 Azimuth FOV</a> . ON #2: Increments at all times.

Parameter	Options	Description				
Sync Angle	0 to 359 Unit: °	<p>Phase lock angle</p> <ul style="list-style-type: none"> <li>To activate this function, check the checkbox and input an azimuth.</li> <li>At every full second, the lidar will rotate to that azimuthal position.</li> </ul> <p> Lidar azimuthal position is defined in <a href="#">Section 1.3 Basic structure</a>.</p> <p>Definition of the full second (detailed in <a href="#">Section B.1 Source of absolute time</a>):</p> <ul style="list-style-type: none"> <li>When GPS is locked, the full second is defined as the rising edge of the GPS PPS signal.</li> <li> When PTP is tracking or locked, the full second is retrieved from the PTP signal. (PPS signal is not required nor used.)</li> <li>When neither GPS nor PTP is locked, the full second is defined as the rising edge of the lidar's internal 1 Hz signal.</li> </ul> <p>To phase-lock multiple lidar units, connect them to the same clock source and set the same sync angle. These lidar units will rotate to the same azimuthal position at every full second.</p>				
Trigger Method	Time-Based (default) Angle-Based	<p>The way laser firings are triggered.</p> <table border="1"> <tbody> <tr> <td>Angle-based</td> <td>Lasers fire every 0.2° at 10 Hz or 0.4° at 20 Hz.</td> </tr> <tr> <td>Time-based</td> <td>Lasers fire every 55.56 μs.</td> </tr> </tbody> </table>	Angle-based	Lasers fire every 0.2° at 10 Hz or 0.4° at 20 Hz.	Time-based	Lasers fire every 55.56 μs.
Angle-based	Lasers fire every 0.2° at 10 Hz or 0.4° at 20 Hz.					
Time-based	Lasers fire every 55.56 μs.					
Noise Filtering	OFF (default) ON	To reduce the scattered false positives (i.e. noise points) in point cloud data.				

Parameter	Options	Description	
Interstitial Points Filtering	OFF (default) ON	To reduce the interstitial points in point cloud data.   Definition of interstitial points: When a beam partially hits a front target's edge and further hits a rear target, the return signal can result in a false point located between both targets.	
Retro Multi-Reflection Filtering	OFF (default) ON	To reduce the false positives at twice the distance of a retroreflector.	
Reflectivity Mapping	Linear Mapping (default) Nonlinear Mapping	Linear Mapping	The <b>Reflectivity</b> field in Point Cloud Data Packets linearly represents target reflectivity (0 to 255%).
		Nonlinear Mapping	The mapping between the <b>Reflectivity</b> field and target reflectivity is nonlinear. This increases the contrast in low-reflectivity areas (see <a href="#">Appendix D Nonlinear reflectivity mapping</a> ).
Standby Mode	In Operation (default) Standby	In Standby mode, the motor stops running and lasers stop firing.	

### 4.2.3. Time sync

#### With GPS selected

Clock Source	<b>GPS</b>
GPS Mode	GPRMC
GPS Destination Port	10110

#### With PTP selected

Clock Source	<b>PTP</b>
Profile	1588v2
Time Offset for Lidar Lock	1
PTP Network Transport	UDP/IP
PTP Domain Number	0
PTP logAnnounceInterval	1
PTP logSyncInterval	1
PTP logMinDelayReqInterval	0

Parameter	Options	Description
Clock Source	GPS (default) PTP	External source of absolute time

**4.2.3.1. With GPS selected**

Parameter	Options	Description
GPS Mode	GPRMC (default) GPGGA	Format of the NMEA data received from the external GPS module (see <a href="#">Section 3.2.2 GPS UDP data</a> )
GPS Baud Rate	9600 19200 38400 115200	-
Destination Port	Default: 10110	Port used for sending GPS Data Packets

**4.2.3.2. With PTP selected**

The lidar does NOT output GPS Data Packets.

Parameter	Options	Description		
Profile	1588v2 (default) 802.1AS 802.1AS Automotive	IEEE timing and synchronization standard		
Time Offset for Lidar Lock	1 to 100 $\mu$ s (integer) Default: 1	Upper limit of the absolute offset between Slave and Master when the lidar is in PTP Locked status; see <a href="#">Section 4.1 Home</a> .		
PTP Network Transport	UDP/IP (default) L2	Network transport protocol		
		<table border="1"> <tbody> <tr> <td>UDP/IP</td> <td>Available only for the 1588v2 profile</td> </tr> <tr> <td>L2</td> <td>Available for all profiles</td> </tr> </tbody> </table>	UDP/IP	Available only for the 1588v2 profile
UDP/IP	Available only for the 1588v2 profile			
L2	Available for all profiles			
Domain Number	0 to 127 (integer) Default: 0	Domain attribute of the local clock		

**When using the 1588v2 profile, these additional parameters can be configured:**

Parameter	Options	Description
PTP logAnnounceInterval	-2 to 3	Time interval between Announce messages Default: 1 (2 seconds)
PTP logSyncInterval	-7 to 3	Time interval between Sync messages Default: 1 (2 seconds)
PTP logMinDelayReqInterval	-7 to 3	Minimum permitted mean time between Delay_Req messages Default: 0 (1 second)

**When using the 802.1AS or 802.1AS Automotive profile:**

Parameter	Options	Description				
Switch Type	TSN (default) Non-TSN	Type of the network switch <table border="1" data-bbox="913 788 2072 908"> <tbody> <tr> <td>TSN</td> <td>Time Sensitive Network, using Peer-to-Peer delay mechanism</td> </tr> <tr> <td>Non-TSN</td> <td>Using End-to-End delay mechanism</td> </tr> </tbody> </table>	TSN	Time Sensitive Network, using Peer-to-Peer delay mechanism	Non-TSN	Using End-to-End delay mechanism
TSN	Time Sensitive Network, using Peer-to-Peer delay mechanism					
Non-TSN	Using End-to-End delay mechanism					

## 4.3. Azimuth FOV

Azimuth FOV Setting	For all channels ▼
<a href="#">Save</a>	

### Button

**Save** Save and execute all the settings on this page.

Parameter	Options	Description
Azimuth FOV Setting	For all channels (default) Multi-section FOV	Configuration mode of the azimuth FOV The lidar outputs valid data only within the specified azimuth FOV ranges.



- The angles in degrees are accurate to the first decimal place.
- If the Start Angle is larger than the End Angle, then the actual range is the union of [Start Angle, 360°) and [0°, End Angle).  
For instance, when the angle range is set to be [270°, 90°), the actual azimuth FOV is [270°, 360°) ∪ [0°, 90°).

### 4.3.1. For all channels

Input a start angle and an end angle to form a continuous angle range [Start, End].

This range applies to all channels.

Azimuth FOV Setting		For all channels
Azimuth FOV for All Channels	Start:	0.0
	End:	360.0
<a href="#">Save</a>		

### 4.3.2. For each channel

Input a Start Angle and an End Angle to form a continuous angle range for each channel.

The [ **Status** ] button for each channel.

- The button is gray by default, indicating that the angle range is [0°, 360°].
- To activate the angle range in the table, click the corresponding button to make it green.

Click the [ **Enable/Disable All** ] button to activate/deactivate the angle ranges of all channels.

Azimuth FOV Setting		For each channel	
Enable/Disable All			
Status	Channel	Start Angle	End Angle
●	1	0.0	0.0
●	2	0.0	0.0
●	3	0.0	0.0



[Save](#)

### 4.3.3. Multi-section FOV

For each channel, input multiple ( $\leq 10$ ) sets of Start Angles and End Angles to form multiple continuous angle ranges.

The [ **Status** ] buttons for each channel:

- are gray by default, indicating that the angle range is  $[0^\circ, 360^\circ]$ .
- To activate the angle range in the table, click the corresponding button to make it green.

Click the [ **Enable/Disable All** ] button to activate/deactivate the angle ranges of all channels.

Azimuth FOV Setting				Multi-section FOV				
Enable/Disable All								
Status	Channel	Azimuth FOV 1		Azimuth FOV 2		...	Azimuth FOV 10	
		Start Angle	End Angle	Start Angle	End Angle	...	Start Angle	End Angle
●	1	0.0	0.0	0.0	0.0	...	0.0	0.0
●	2	0.0	0.0	0.0	0.0	...	0.0	0.0
●	...	0.0	0.0	0.0	0.0	...	0.0	0.0
●	64	0.0	0.0	0.0	0.0	...	0.0	0.0

[Save](#)

## 4.4. Operation statistics

These operating parameters are displayed in real time:

Start-Up Counts	510
Internal Temperature	32.10°C
System Uptime	0 h 5 min
Total Operation Time	559 h 43 min
Internal Temperature	Operation Time
< -40°C	0 h 1 min
-40 to -20°C	0 h 46 min
...	...
100 to 120°C	1 h 44 min
> 120°C	0 h 0 min

## 4.5. Upgrade



- Before upgrading, please contact Hesai technical support to obtain the .patch file.
- It is recommended to place a protective cover or other opaque material over the lidar's cover lens when upgrading.
- The instructions for downgrading are the same as those for upgrading.

### Upgrade steps

1. Click the [ **Upload** ] button and select the .patch file to start upgrade.
2. Wait for the process to be 100% complete. The lidar will automatically reboot.
3. The latest version numbers will display in "Upgrade" and "Home" pages.



If the upgrade fails, hard restart the lidar and try again.

### Buttons

<b>Upload</b>	To upload the .patch file
<b>Restart</b>	Software reboot Afterward, the Start-Up Counts in the Operation Statistics page increments by 1; see <a href="#">Section 4.4 Operation statistics</a> .

Parameter	Current version
Software version	2.10.8
Firmware of sensor version	4.3.44b
Firmware of controller version	5.32
Upgrade log	-



The above version numbers may be different from the actual ones. Please refer to the web page of the lidar.

## 5. Maintenance

The lidar's cover lens is made of plastic (polycarbonate, PC), similar to the material used for car lamps.

- Do NOT wipe the cover lens when it is dry, nor use abrasive cleaners. Doing so can damage the optical coating.
- Do NOT use organic cleaners, which can damage the cover lens and even cause cracking.
  - Organic cleaners include but are not limited to tar removers, self-cleaning agents, adhesive removers, coating removers, foam cleaners, iron powder removers for car paint, glass cleaners, thinning agents, de-icers, paint surface treatment agents, alcohol, and vinegar.
  - If organic cleaners may be present when cleaning the equipment or performing related operations, please protect the cover lens to prevent any contact with organic cleaners.
- Do NOT apply excessive force to the lidar, as this can damage the cover lens.
  - If a pressure washer is used to clean the cover lens, make sure the distance between the nozzle and the cover lens remains at least 60 cm.
  - Using automatic cleaning devices that are not specifically designed for lidars may pose risks. Please contact Hesai technical support for assessment.
- After prolonged exposure to strong sunlight and high temperatures, the cover lens should NOT be cleaned immediately.
- If snow or ice accumulates on the cover lens, do NOT use a pressure washer or ice scraper.
  - A small broom is recommended to remove snow.
  - A solvent-free (i.e., free of organic solvents) ice removal spray is recommended to remove ice; alternatively, wait for the ice to melt by itself.
- Do NOT wax the cover lens.



Please regularly check on the cover lens, considering your use frequency, storage environment, and climate conditions.



- If foreign objects (such as dust, fingerprints, or oil stains) are found on the cover lens, make sure to clean them.
- If corrosive foreign objects (such as insect remains, bird droppings, tree resin, road dust, industrial dust, asphalt, soot particles, and road salt) are found on the cover lens, make sure to clean them immediately.

### Cleaning procedure

1. Make sure the lidar is powered OFF.

2. Choose an appropriate cleaning agent:
  - For light stains, use room temperature water.
  - For heavier stains, use a mild soap solution (no more than two tablespoons of soap per quart or liter of water).
  - For stubborn stains, use a solvent-free (i.e., free of organic solvents), pH-neutral detergent at room temperature, such as car shampoo.
3. Take a clean soft sponge or anti-static microfiber cloth, dampen it with the chosen cleaning agent, and gently wipe the dirty area on the cover lens back and forth.
4. For stubborn stains, cover the dirty area with the dampened sponge or cloth to soften the stains before wiping.
5. Immediately after removing the stains, rinse the cover lens with clean water. Then, use a clean soft sponge or microfiber cloth to gently wipe away any remaining liquid (which may contain residual cleaning agents or contaminants).

## 6. Troubleshooting

If the following procedures cannot solve your problem, please contact Hesai technical support.

Symptoms	Points to check
Indicator light is off on the connection box.	<p>Make sure that the following conditions are met:</p> <ul style="list-style-type: none"> <li>• The power adapter is properly connected and in good condition.</li> <li>• The connection box is intact.</li> <li>• The input voltage and input current satisfy the requirements in <a href="#">Section 2.3 Connection box (optional)</a>.</li> </ul> <p>Afterward, power on the lidar again and check if the symptom persists</p>
Motor is not running.	<p>Make sure that the following conditions are met:</p> <ul style="list-style-type: none"> <li>• The power adapter is properly connected and in good condition.</li> <li>• The input voltage and input current satisfy the requirements in <a href="#">Section 1.5 Specifications</a>.</li> <li>• The lidar can be accessed using Web Control (see <a href="#">Cannot open Web Control</a>).</li> <li>• The lidar is not in standby mode; this can be confirmed using Web Control or PTC commands.</li> <li>• If a connection box is used, the connection box is intact.</li> </ul> <p>Afterward, power on the lidar again and check if the symptom persists.</p>
Motor is running, but no output data is received, neither by Wireshark nor by PandarView 2.	<p>Make sure that the following conditions are met:</p> <ul style="list-style-type: none"> <li>• The Ethernet cable is properly connected (by unplugging and plugging again).</li> <li>• Destination IP is correctly set; this can be confirmed using Web Control or PTC commands.</li> <li>• Firmware version is correct; this can be confirmed using Web Control or PTC commands.</li> <li>• Azimuth FOV is correctly set; this can be confirmed using Web Control or PTC commands.</li> <li>• The lidar is emitting laser light; this can be confirmed using an infrared camera, an infrared sensor card, or a phone camera without an infrared filter.</li> </ul> <p>Afterward, power on the lidar again and check if the symptom persists.</p>

Symptoms	Points to check
Output data can be received by Wireshark but not by PandarView 2.	<p>Make sure that the following conditions are met:</p> <ul style="list-style-type: none"> <li>• Lidar Destination Port is correctly set; this can be confirmed using Web Control or PTC commands.</li> <li>• If VLAN is enabled, the PC's VLAN ID should be the same as the lidar's; this can be checked using Web Control or PTC commands.</li> <li>• The PC's firewall for public networks is turned off, or PandarView 2 is added to the firewall exceptions.</li> <li>• The latest PandarView 2 is installed (see <a href="#">Downloads page of Hesai's official website</a> or contact Hesai technical support).</li> </ul> <p>Afterward, power on the lidar again and check if the symptom persists.</p>
Cannot open Web Control.	<p>Make sure that the following conditions are met:</p> <ul style="list-style-type: none"> <li>• Ethernet cable is properly connected (by unplugging and plugging again).</li> <li>• The lidar's IP is in the same subnet with the PC's (WireShark may be used to check the lidar's IP that broadcasts data packets).</li> <li>• If VLAN is enabled, the PC's VLAN ID should be the same as the lidar's; this can be checked using Web Control or PTC commands.</li> </ul> <p>Afterward, follow these steps:</p> <ol style="list-style-type: none"> <li>1. Restart the PC or connect the lidar to another PC.</li> <li>2. Power on the lidar again and check if the symptom persists.</li> </ol>

Symptoms	Points to check
<p>The point cloud is abnormal, showing obviously misaligned points, flashing points, or incomplete FOV.</p>	<p>Make sure that the following conditions are met:</p> <ul style="list-style-type: none"> <li>• The lidar's cover lens is clean. If not, refer to <a href="#">Section 5 Maintenance</a> for the cleaning method.</li> <li>• The lidar's angle correction file is imported (refer to <i>PandarView 2 User Manual</i>).</li> <li>• Azimuth FOV is properly set; this can be confirmed using Web Control or PTC commands.</li> <li>• Spin Rate is steady; this can be confirmed either by checking the <b>Motor Speed</b> field (if available) in Point Cloud Data Packets, or by using Web Control, PandarView 2 or PTC commands.</li> <li>• The lidar's internal temperature is between <math>-20^{\circ}\text{C}</math> and <math>95^{\circ}\text{C}</math>; this can be confirmed using Web Control, PandarView 2 or PTC commands.</li> </ul> <p>Afterward, check for packet loss.</p> <p>If no packet is lost yet the point cloud flashes, please follow these steps:</p> <ol style="list-style-type: none"> <li>1. Update PandarView 2 to the latest version (see <a href="#">Downloads page of Hesai's official website</a> or contact Hesai technical support).</li> <li>2. Restart the PC.</li> </ol> <p>If the point cloud is still abnormal, try these steps:</p> <ol style="list-style-type: none"> <li>1. Connect the lidar to another PC and another network.</li> <li>2. Power on again and check if the symptom persists.</li> </ol>



Symptoms	Points to check
<p>The number of data packets received is abnormal, indicating missing packets.</p>	<p>Make sure that the following conditions are met:</p> <ul style="list-style-type: none"> <li>• Azimuth FOV is properly set; this can be confirmed using Web Control or PTC commands.</li> <li>• Spin Rate is steady; this can be confirmed either by checking the <b>Motor Speed</b> field (if available) in Point Cloud Data Packets, or by using Web Control, PandarView 2 or PTC commands.</li> <li>• The lidar's internal temperature is between <math>-20^{\circ}\text{C}</math> and <math>95^{\circ}\text{C}</math>; this can be confirmed using Web Control, PandarView 2 or PTC commands.</li> <li>• Ethernet is not overloaded.</li> <li>• No switch is connected to the network (the data transmitted from other devices may cause network congestion and packet loss).</li> </ul> <p>Afterward, follow these steps:</p> <ol style="list-style-type: none"> <li>1. Connect the PC to no other devices but the lidar and check for packet loss.</li> <li>2. Power on the lidar again and check if the symptom persists.</li> </ol>
<p>GPS cannot be locked.</p>	<p>Make sure that the following conditions are met:</p> <ul style="list-style-type: none"> <li>• GPS receiver is properly connected.</li> <li>• PPS signal is connected to the lidar.</li> <li>• GPS Destination Port is correctly set; this can be confirmed using Web Control or PTC commands.</li> <li>• The GPS signals satisfy the electrical requirements in <a href="#">Section 2.2 Electrical interface</a> and <a href="#">Section 2.3 Connection box (optional)</a>.</li> </ul> <p>Afterward, power on the lidar again and check if the symptom persists.</p>

## Appendix A: Channel distribution data

### Notes to the table

<b>Channel number</b>	Counts from 1, top to bottom.
<b>Angular position</b>	The design values of each channel's horizontal (azimuth) angle offset and vertical (elevation) angle. <ul style="list-style-type: none"><li>• The accurate values are recorded in this lidar unit's angle correction file.</li><li>• To analyze point cloud data, refer to <a href="#">Section 3.1.4 Point cloud data analysis method</a>.</li></ul>
<b>Instrumented range</b>	Actual measurement range, confined by the allocated Time of Flight (ToF) for each channel

Channel number	Horizontal angle offset (azimuth)	Vertical angle (elevation)	Instrumented range	Ranging capability with reflectivity
1	-1.042°	14.882°	130 m	200 m @20%
2	-1.042°	11.032°	130 m	200 m @20%
3	-1.042°	8.059°	130 m	200 m @20%
4	-1.042°	5.057°	130 m	200 m @20%
5	-1.042°	3.040°	130 m	200 m @20%
6	-1.042°	2.028°	130 m	200 m @20%
7	1.042°	1.860°	130 m	200 m @20%
8	3.125°	1.688°	230 m	200 m @20%
9	5.208°	1.522°	130 m	200 m @20%
10	-5.208°	1.351°	230 m	200 m @20%
11	-3.125°	1.184°	230 m	200 m @20%
12	-1.042°	1.013°	230 m	200 m @10%
13	1.042°	0.846°	230 m	200 m @10%
14	3.125°	0.675°	230 m	200 m @10%
15	5.208°	0.508°	230 m	200 m @10%
16	-5.208°	0.337°	230 m	200 m @10%
17	-3.125°	0.169°	230 m	200 m @10%
18	-1.042°	0.000°	230 m	200 m @10%
19	1.042°	-0.169°	230 m	200 m @10%
20	3.125°	-0.337°	230 m	200 m @10%

Channel number	Horizontal angle offset (azimuth)	Vertical angle (elevation)	Instrumented range	Ranging capability with reflectivity
21	5.208°	-0.508°	230 m	200 m @10%
22	-5.208°	-0.675°	230 m	200 m @10%
23	-3.125°	-0.845°	230 m	200 m @10%
24	-1.042°	-1.013°	230 m	200 m @10%
25	1.042°	-1.184°	230 m	200 m @10%
26	3.125°	-1.351°	230 m	200 m @10%
27	5.208°	-1.522°	230 m	200 m @10%
28	-5.208°	-1.688°	230 m	200 m @10%
29	-3.125°	-1.860°	230 m	200 m @10%
30	-1.042°	-2.028°	230 m	200 m @10%
31	1.042°	-2.198°	230 m	200 m @20%
32	3.125°	-2.365°	230 m	200 m @20%
33	5.208°	-2.536°	230 m	200 m @20%
34	-5.208°	-2.700°	230 m	200 m @20%
35	-3.125°	-2.873°	230 m	200 m @20%
36	-1.042°	-3.040°	230 m	200 m @20%
37	1.042°	-3.210°	230 m	200 m @20%
38	3.125°	-3.375°	230 m	200 m @20%
39	5.208°	-3.548°	130 m	200 m @20%
40	-5.208°	-3.712°	230 m	200 m @20%

Channel number	Horizontal angle offset (azimuth)	Vertical angle (elevation)	Instrumented range	Ranging capability with reflectivity
41	-3.125°	-3.884°	130 m	200 m @20%
42	-1.042°	-4.050°	230 m	200 m @20%
43	1.042°	-4.221°	130 m	200 m @20%
44	3.125°	-4.385°	130 m	200 m @20%
45	5.208°	-4.558°	130 m	200 m @20%
46	-5.208°	-4.720°	130 m	200 m @20%
47	-3.125°	-4.892°	130 m	200 m @20%
48	-1.042°	-5.057°	130 m	200 m @20%
49	1.042°	-5.229°	130 m	200 m @20%
50	3.125°	-5.391°	130 m	200 m @20%
51	5.208°	-5.565°	130 m	200 m @20%
52	-5.208°	-5.726°	130 m	200 m @20%
53	-3.125°	-5.898°	130 m	200 m @20%
54	-1.042°	-6.061°	130 m	200 m @20%
55	-1.042°	-7.063°	130 m	200 m @20%
56	-1.042°	-8.059°	130 m	200 m @20%
57	-1.042°	-9.060°	130 m	200 m @20%
58	-1.042°	-9.885°	130 m	200 m @20%
59	-1.042°	-11.032°	130 m	200 m @20%
60	-1.042°	-12.006°	130 m	200 m @20%

Channel number	Horizontal angle offset (azimuth)	Vertical angle (elevation)	Instrumented range	Ranging capability with reflectivity
61	-1.042°	-12.974°	130 m	200 m @20%
62	-1.042°	-13.930°	130 m	200 m @20%
63	-1.042°	-18.889°	130 m	200 m @20%
64	-1.042°	-24.897°	130 m	200 m @20%

## Appendix B: Absolute time of point cloud data

### B.1. Source of absolute time

The lidar retrieves the current absolute time by connecting to an external clock source.

#### B.1.1. GPS as the clock source

The lidar connects to a third-party GPS module to obtain pulse-per-second (PPS) signals and NMEA sentences.

- NMEA sentence (\$GPRMC or \$GPGGA) can be selected using Web Control or PTC commands.
- The signal status of GPS PPS and NMEA can be checked using Web Control or PTC commands.
- The timing requirements of PPS and NMEA are shown in [Section 2.2.1 Pin description](#).
- Each rising edge of the lidar's internal 1 Hz signal triggers a GPS Data Packet. The data format is detailed in [Section 3.2 GPS Data Packet](#).

The absolute time is updated as follows:

NMEA status	Date and time (accurate to the second)	Lidar behavior
Unlocked (Initial)	Virtual	Because the lidar has not been locked before, it starts counting from a <b>virtual UTC</b> (such as 2000-01-01 00:00:00) using the lidar's internal 1 Hz signal.
Locked	Synchronized	At each rising edge of the internal 1 Hz signal, the lidar obtains the actual date and time by performing these two steps: <ol style="list-style-type: none"> <li>1. Extract the date and time from the previous NMEA message.</li> <li>2. Add 1 full second.</li> </ol>
Unlocked (Lost)	Drifting	When the lidar goes from Locked to Unlocked, it starts counting from <b>the last synchronized time</b> using the lidar's internal 1 Hz signal. This absolute time will gradually drift from the actual GPS time.

PPS status	$\mu$ s time	Lidar behavior
Unlocked (Initial)	Not synchronized	The lidar's internal 1 Hz signal is not aligned with the GPS second.
Locked	Synchronized	The rising edge of the lidar's internal 1 Hz signal is aligned with the rising edge of the PPS signal (i.e. the start of each GPS second).
Unlocked (Lost)	Drifting	The lidar counts the absolute time using the internal 1 Hz signal. This absolute time will gradually drift from the actual GPS second.

### B.1.2. PTP as the clock source

The lidar connects to a third-party PTP master to obtain PTP signal.



- PPS signal is not required nor used.
- PTP can be configured using Web Control or PTC commands.
- The status of PTP signal can be found using Web Control or PTC commands.
- The lidar does not output GPS Data Packets.

The absolute time is updated as follows:

PTP status	Date and time (accurate to the microsecond)	Lidar behavior
Free run	Virtual	Because the lidar has not been locked before, it starts counting from <b>a virtual UTC</b> (such as 2000-01-01 00:00:00) using the lidar's internal 1 Hz signal.
Tracking or Locked	Synchronized	The lidar extracts the actual date and time from the PTP Master's messages.
Frozen	Drifting	When the lidar goes from Tracking/Locked to Frozen, it starts counting from <b>the last synchronized time</b> using the lidar's internal 1 Hz signal. This absolute time will gradually drift from the actual PTP time.





- PTP is a Plug & Play protocol; the lidar works as a PTP slave device and requires no additional setup.
- The **Timestamp** and **Date & Time** fields in Point Cloud Data Packets strictly follow the PTP master device. Certain PTP master devices may have a specified offset from the lidar's time output. Please verify the configuration and calibration of your PTP master device.

## B.2. Absolute time of the Point Cloud Data Packets

The absolute time of the Point Cloud Data Packets is  $t_0 = t_s + t_{ms}$ , where:

- $t_s$  is the whole second part (see the **Date & Time** field).
- $t_{ms}$  is the microsecond part (see the **Timestamp** field).

The definition of the above fields is in [Section 3.1.2.3 Tail](#).

## B.3. End time of each block

Given the absolute time of a Point Cloud Data Packet  $t_0$ , the end time of each block (i.e., the time when the last firing ends) can be calculated.

### Single Return mode

Block	End time ( $\mu$ s)
Block 6	$t_0 - 42.58$
Block N	$t_0 - 42.58 - 55.56 \times (6 - N)$
Block 3	$t_0 - 42.58 - 55.56 \times 3$
Block 2	$t_0 - 42.58 - 55.56 \times 4$
Block 1	$t_0 - 42.58 - 55.56 \times 5$

### Dual Return mode

Block	End time ( $\mu$ s)
Block 6 & Block 5	$t_0 - 42.58$
Block 4 & Block 3	$t_0 - 42.58 - 55.56 \times 1$
Block 2 & Block 1	$t_0 - 42.58 - 55.56 \times 2$

## B.4. Laser firing time of each channel

Assume that the end time of Block  $m$  is  $T(m)$ ,  $m \in \{1, 2, \dots, 6\}$ , then the laser firing time of **Channel  $n$  in Block  $m$**  is

$$t(m, n) = T(m) + \Delta t(n), n \in \{1, 2, \dots, 64\}.$$

The lookup table of the firing time offsets  $\Delta t(n)$  is shown below.

Firing sequence	Channel No.	$\Delta t(n)$ ( $\mu\text{s}$ )
1	12	-54.668
1	40	-54.668
2	18	-52.7
2	38	-52.7
3	11	-50.732
3	26	-50.732
4	17	-48.764
4	32	-48.764
5	8	-46.796
5	23	-46.796
6	14	-44.828
6	29	-44.828
7	20	-42.86
7	35	-42.86
8	13	-40.892
8	28	-40.892

#### B.4. Laser firing time of each channel

Firing sequence	Channel No.	$\Delta t(n)$ ( $\mu s$ )
9	19	-38.924
9	34	-38.924
10	10	-36.956
10	25	-36.956
11	16	-34.988
11	31	-34.988
12	22	-33.02
12	37	-33.02
13	15	-31.052
13	30	-31.052
14	21	-29.084
14	36	-29.084
15	27	-27.116
15	42	-27.116
16	24	-25.148
16	33	-25.148
17	1	-23.18
17	44	-23.18
18	2	-21.876
18	46	-21.876
19	3	-20.572

#### B.4. Laser firing time of each channel

Firing sequence	Channel No.	$\Delta t(n)$ ( $\mu s$ )
19	52	-20.572
20	4	-19.268
20	50	-19.268
21	5	-17.964
21	48	-17.964
22	6	-16.66
22	54	-16.66
23	41	-15.356
23	58	-15.356
24	47	-14.052
24	62	-14.052
25	53	-12.748
25	64	-12.748
26	7	-11.444
26	56	-11.444
27	43	-10.14
27	59	-10.14
28	49	-8.836
28	63	-8.836
29	9	-7.532
29	55	-7.532

#### B.4. Laser firing time of each channel

Firing sequence	Channel No.	$\Delta t(n)$ ( $\mu s$ )
30	39	-6.228
30	57	-6.228
31	45	-4.924
31	60	-4.924
32	51	-3.62
32	61	-3.62

# Appendix C: Phoenix connector

Phoenix contact can be used as the lidar's communication connector, in place of the default Lemo contact [Section 2.2 Electrical interface](#).

Phoenix part number:  
SACC-M12MS-8CON-PG 9-SH - 1511857 (male, on the lidar)  
SACC-M12FS-8CON-PG 9-SH - 1511860 (female, on the connection box)

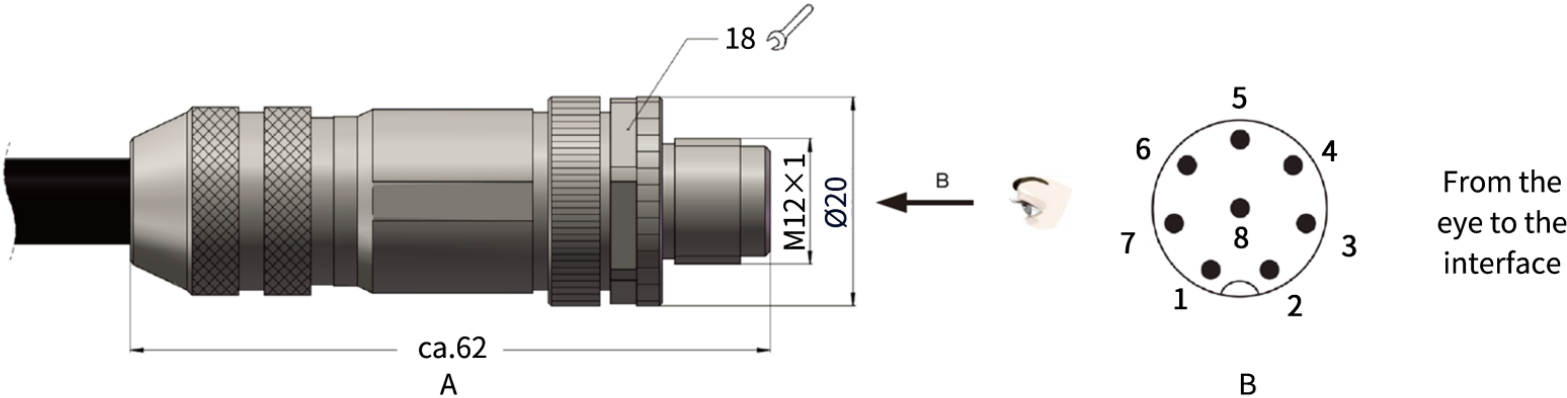

Figure 19. Phoenix connector (unit: mm)

### Pin description

Pin number	Signal	Wire color	Voltage
1	Ethernet RX-	Blue	-1 V to 1 V
2	Ethernet RX+	Blue/White	-1 V to 1 V
3	Ethernet TX-	Orange	-1 V to 1 V
4	Ethernet TX+	Orange/White	-1 V to 1 V

Pin number	Signal	Wire color	Voltage
5	GPS NMEA	White	-13 V to +13 V
6	GPS PPS	Yellow	3.3 V/5 V
7	+12 V	Red	12 V
8	Ground (Return)	Black	-



## Appendix D: Nonlinear reflectivity mapping

By default, the **Reflectivity** field in Point Cloud Data Packets (see [Section 3.1.2.2 Body](#)) linearly represents target reflectivity.

- Range of the **Reflectivity** field value: 0 to 255
- Range of target reflectivity: 0 to 255%

Alternatively, users may choose the Nonlinear Mapping mode using Web Control or PTC commands.

Nonlinear mapping increases the contrast in the low-reflectivity region.

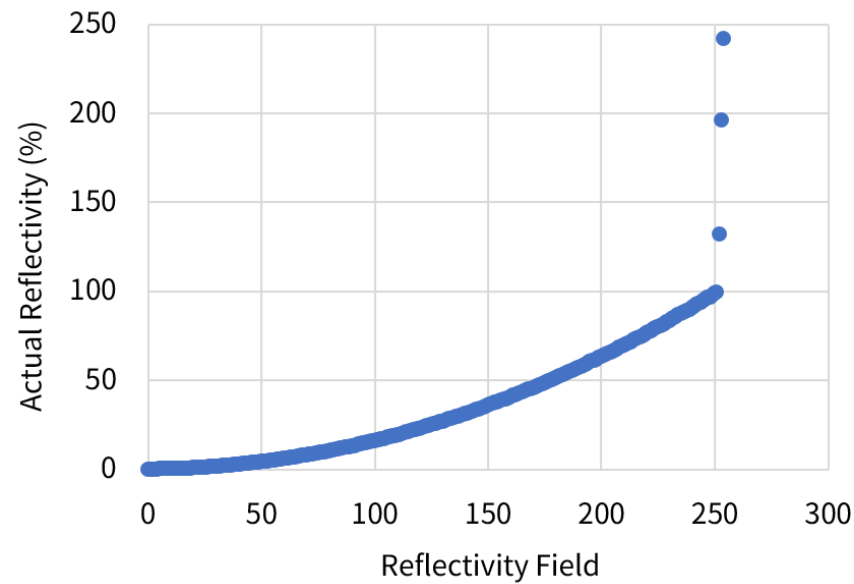

Figure 20. Nonlinear mapping

**Nonlinear mapping**

Reflectivity field	Actual reflectivity %	Reflectivity field	Actual reflectivity %	Reflectivity field	Actual reflectivity %	Reflectivity field	Actual reflectivity %
0	0	1	0.01	2	0.02	3	0.03
4	0.04	5	0.05	6	0.08	7	0.11
8	0.13	9	0.15	10	0.19	11	0.23
12	0.26	13	0.29	14	0.34	15	0.39
16	0.44	17	0.5	18	0.56	19	0.61
20	0.67	21	0.75	22	0.81	23	0.87
24	0.95	25	1.05	26	1.15	27	1.25
28	1.35	29	1.45	30	1.55	31	1.65
32	1.75	33	1.85	34	1.95	35	2.06
36	2.19	37	2.31	38	2.44	39	2.56
40	2.69	41	2.81	42	2.94	43	3.07
44	3.21	45	3.36	46	3.5	47	3.64
48	3.79	49	3.93	50	4.08	51	4.25
52	4.42	53	4.58	54	4.75	55	4.92
56	5.1	57	5.3	58	5.5	59	5.7
60	5.9	61	6.1	62	6.3	63	6.5
64	6.7	65	6.9	66	7.1	67	7.3
68	7.5	69	7.7	70	7.9	71	8.12
72	8.37	73	8.62	74	8.87	75	9.1

Appendix D: Nonlinear reflectivity mapping

Reflectivity field	Actual reflectivity %	Reflectivity field	Actual reflectivity %	Reflectivity field	Actual reflectivity %	Reflectivity field	Actual reflectivity %
76	9.3	77	9.5	78	9.7	79	9.9
80	10.17	81	10.5	82	10.83	83	11.12
84	11.37	85	11.62	86	11.87	87	12.12
88	12.37	89	12.62	90	12.87	91	13.17
92	13.5	93	13.83	94	14.17	95	14.5
96	14.83	97	15.12	98	15.37	99	15.62
100	15.87	101	16.17	102	16.5	103	16.83
104	17.17	105	17.5	106	17.83	107	18.17
108	18.5	109	18.83	110	19.17	111	19.5
112	19.83	113	20.25	114	20.75	115	21.17
116	21.5	117	21.83	118	22.17	119	22.5
120	22.83	121	23.25	122	23.75	123	24.17
124	24.5	125	24.83	126	25.25	127	25.75
128	26.17	129	26.5	130	26.83	131	27.25
132	27.75	133	28.17	134	28.5	135	28.83
136	29.25	137	29.75	138	30.25	139	30.75
140	31.17	141	31.5	142	31.83	143	32.25
144	32.75	145	33.25	146	33.75	147	34.25
148	34.75	149	35.25	150	35.75	151	36.25
152	36.75	153	37.25	154	37.75	155	38.25

Appendix D: Nonlinear reflectivity mapping

Reflectivity field	Actual reflectivity %	Reflectivity field	Actual reflectivity %	Reflectivity field	Actual reflectivity %	Reflectivity field	Actual reflectivity %
156	38.75	157	39.17	158	39.5	159	39.83
160	40.5	161	41.25	162	41.75	163	42.25
164	42.75	165	43.25	166	43.75	167	44.25
168	44.75	169	45.25	170	45.75	171	46.25
172	46.75	173	47.25	174	47.75	175	48.25
176	48.75	177	49.5	178	50.25	179	50.75
180	51.25	181	51.75	182	52.25	183	52.75
184	53.5	185	54.25	186	54.75	187	55.25
188	55.75	189	56.5	190	57.25	191	57.75
192	58.25	193	58.75	194	59.5	195	60.25
196	60.75	197	61.25	198	61.75	199	62.5
200	63.25	201	63.75	202	64.5	203	65.25
204	65.75	205	66.25	206	66.75	207	67.5
208	68.25	209	68.75	210	69.5	211	70.25
212	70.75	213	71.5	214	72.25	215	72.75
216	73.5	217	74.25	218	74.75	219	75.5
220	76.5	221	77.25	222	77.75	223	78.5
224	79.25	225	79.75	226	80.5	227	81.25
228	81.75	229	82.5	230	83.5	231	84.25
232	84.75	233	85.5	234	86.5	235	87.25

Appendix D: Nonlinear reflectivity mapping

Reflectivity field	Actual reflectivity %	Reflectivity field	Actual reflectivity %	Reflectivity field	Actual reflectivity %	Reflectivity field	Actual reflectivity %
236	87.75	237	88.5	238	89.25	239	89.75
240	90.5	241	91.5	242	92.5	243	93.25
244	93.75	245	94.5	246	95.5	247	96.25
248	96.75	249	97.5	250	98.5	251	99.5
252	132	253	196	254	242	-	-

## Appendix E: Legal notice

Copyright © 2017-2024 Hesai Technology Co., Ltd.

All rights reserved. Use or reproduction of this manual in parts or in its entirety without the authorization of Hesai is prohibited.

Hesai Technology makes no representations or warranties, either expressed or implied, with respect to the contents hereof and specifically disclaims any warranties, merchantability, or fitness for any particular purpose. Further, Hesai Technology reserves the right to revise this publication and to make changes from time to time in the contents hereof without obligation to notify any person of such revisions or changes.

HESAI and HESAI logo are registered trademarks of Hesai Technology. All other trademarks, service marks, and company names in this manual or on Hesai's official website are properties of their respective owners.

The software included in this product contains the copyright that is registered under Hesai Technology. Any third party is not permitted, except as expressly permitted by the licensor or expressly required by applicable law, to decompile, reverse engineer, disassemble, modify, rent, lease, loan, distribute, sublicense, create derivative works based on the whole or any part of the software.

Hesai Product Warranty Service Manual is on the Warranty Policy page of Hesai's official website: <https://www.hesaitech.com/warranty-policy/>

## Hesai Technology Co., Ltd.

Phone: +86 400 805 1233

Website: [www.hesaitech.com](http://www.hesaitech.com)

Address: Building A, Haisu Culture Plaza, Shanghai, China

Business Email: [info@hesaitech.com](mailto:info@hesaitech.com)

Service Email: [service@hesaitech.com](mailto:service@hesaitech.com)